

Installation Instructions

Sartorius Weigh Cells

Models WZA...-N, WZA...-NC, WZA224-ND

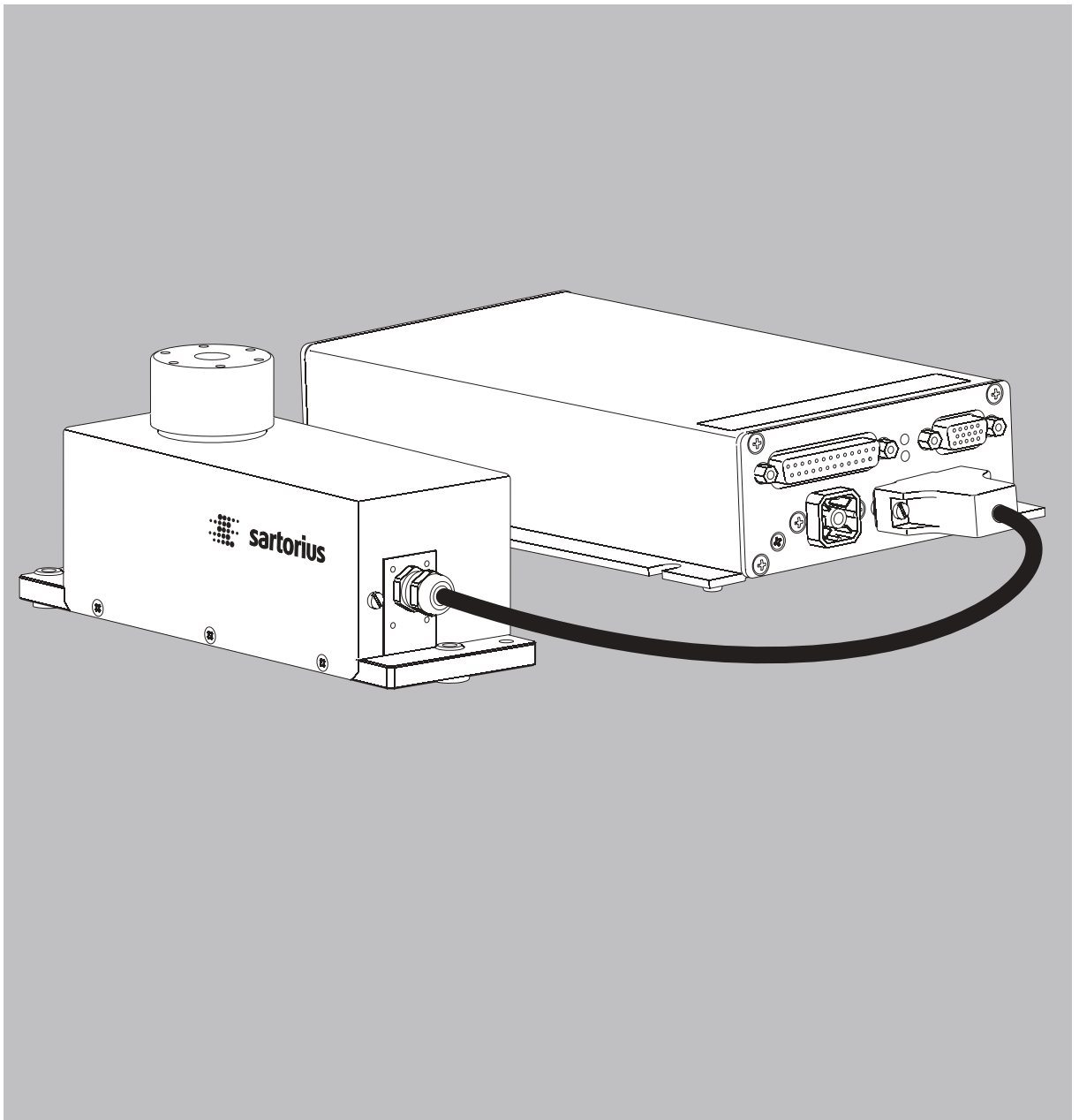

Contents 2

Warning and Safety Instructions . . . 3

General View of the Equipment 3

Installation 5

Storage and Shipping Conditions . . . 5

Incoming Inspection 5

Equipment Supplied 5

Installation Instructions 5

Connecting the Weigh Cell
to the Electronics Module 5

Connecting an Optional Display
and Control Unit 5

Connecting the Weigh Cell
to AC Power 6

Placing Components on the Weigh Cell 7

Leveling the Weigh Cell 9

Operation 10

Notes on Analytical Weighing 10

Below-Cell Weighing 11

Configuration 14

Parameter Settings (Overview) 17

Data interface port: RS-232 24

Pin Assignment Chart 27

Cabling Diagram 28

Troubleshooting Guide 29

Overview 30

Specifications 30

Dimensions (Scale Drawings) 31

Accessories (Options) 37

Declaration of Conformity 38

Form: Return delivery 42

Decontamination Declaration. 43

Intended Use

- The weigh cells have been developed for use in measuring devices and production machinery
- High-precision weighing within limited space
- Precise weight determination on active production lines

System Description

The products are comprised of two components:

- Compact weigh cell that can be affixed to a smooth, even surface.
- Electronics module

- Model WZ...-NC weigh cells have a built-in calibration weight and can be calibrated and adjusted any time by transmitting a control command or at the press of a key using the optional YAC01ED display and control unit or the CAS-Suite software.

- These compact weigh cells can be used to determine weights within restricted space.

Safety

- Once the weigh cell has been installed, the entire product must be checked for the following:
 - Compliance with directives and standards for electrical apparatus
 - Electromagnetic compatibility of the complete weighing instrument
 - Compliance with mandatory safety regulations.
- Read these installation instructions thoroughly before using your weigh cell. That way you will prevent damage to the equipment.
- These installation instructions describe only the technological specifications of the weigh cell and the conditions that must be observed during installation.

△ Always make sure that the equipment is disconnected from power before performing any work on it!

△ The equipment may be opened only by trained service technicians who follow Sartorius' standard operating procedures.

Installation

- △ Do not use this equipment in hazardous areas, zones exposed to explosive gases or dusts, nor areas exposed to potentially explosive materials.
- △ Use of the weigh cell in areas where medical equipment is operated is not permitted.
- △ Replacement of the weigh cell and electronics module:
Only connect devices that are made to be operated together. Pay attention that the serial numbers match.
- △ Any improper handling, modifications or installation work will result in forfeiture of all claims under the warranty.
- △ If you use electrical equipment in installations and under ambient conditions requiring higher safety standards, you must comply with the provisions as specified in the applicable regulations for installation in your country.

- Warning: RS-232 cables purchased from other manufacturers often have incorrect pin assignments for use with Sartorius equipment. Therefore, be sure to check the pin assignments before connecting the cable, and disconnect any lines assigned differently.

- Note on Installation:
The operator shall be responsible for any modifications to Sartorius equipment or connections of cables not supplied by Sartorius and must check and, if necessary, correct these modifications.
Information on operational quality is available on request from Sartorius (in line with norms pertaining to immunity).

- If there is visible damage to the components:
Disconnect from the supply voltage and replace the weigh cell and electronics module:

Do not expose the power supply to aggressive chemical vapors or to unnecessarily extreme temperatures, moisture, shocks, or vibration.

- Please contact the Sartorius customer service center should any problems arise with your device.

Hotline

- Please direct technical questions on design, specifications and installation to your operating partner or directly to Sartorius, at the hotline:
Fax: +49 (0) 551/308-4440
Telephone: +49 (0) 551/308-4449

General View of the Equipment

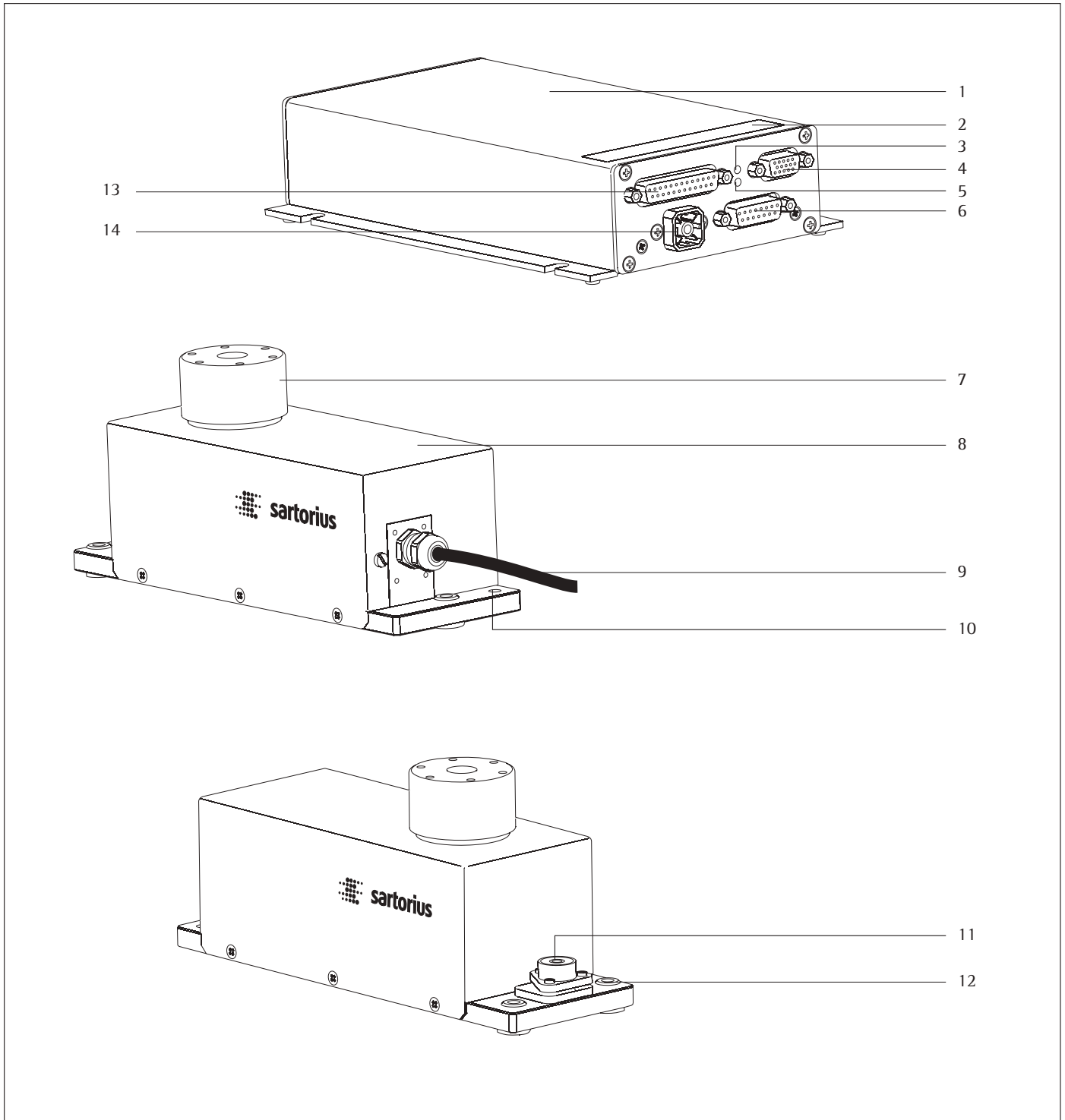

Pos.	Designation
1	Electronics module
2	Plate: Interface description
3	LED: RxD/Supply voltage (yellow)
4	Female connector for the optional display unit
5	LED: TxD (red)
6	Female connector for weigh cell
7	Load receptor
8	Weigh cell
9	Connector (male) for electronics module
10	Threaded hole for equipotential bonding terminal
11	Level indicator
12	Threaded hole (M6) for mounting the weigh cell
13	Data Interface
14	DC jack

General View of the Equipment

WZA25-NC

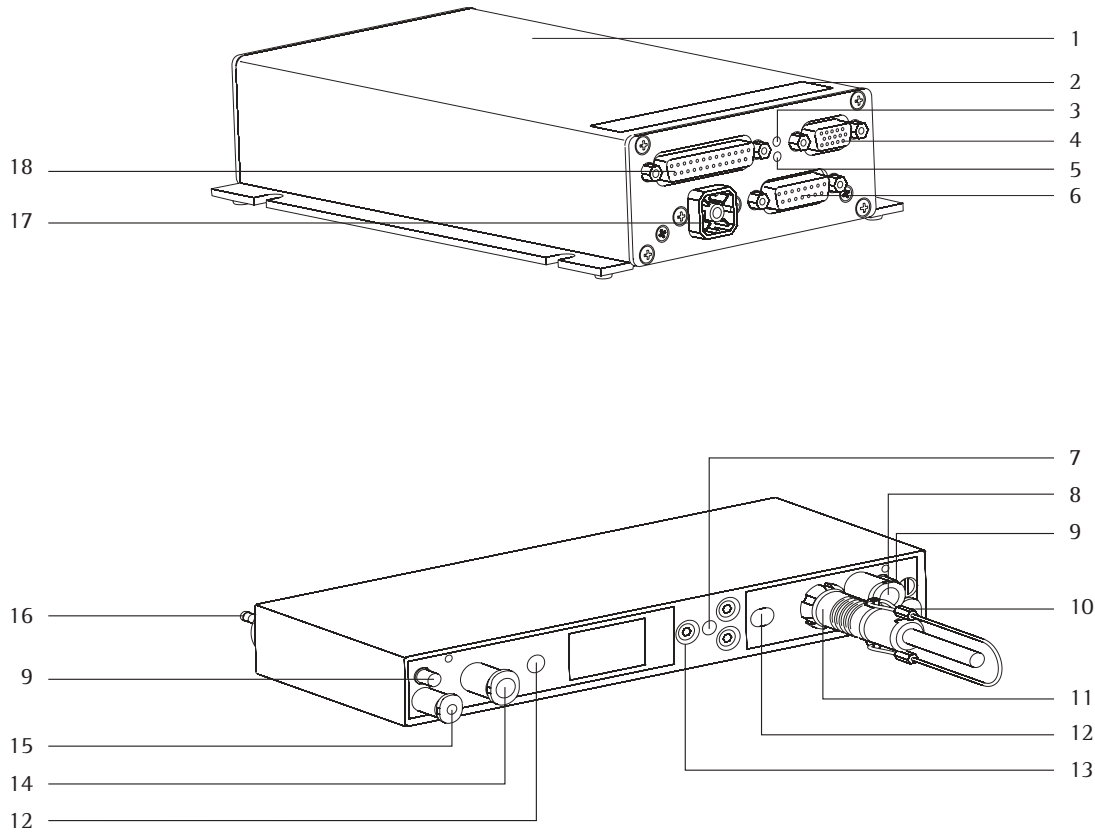

Pos.	Designation
1	Electronics module
2	Plate: Interface description
3	LED: RxD/Supply voltage (yellow)
4	Female connector for the optional display unit
5	LED: TxD (red)
6	Female connector for weigh cell
7	Threaded hole for mounting
8	Overpressure outlet 50 mbar, Ø 6 mm
9	Pressure outlet for 10 and 15
10	Pressure inlet closing mechanism 6 bar, Ø 3 mm
11	Electrical connection
12	Positioning holes
13	Mounting surface
14	Overpressure inlet 50 mbar, Ø 6 mm
15	Pressure inlet Cal.-weight circuit mechanism 6 bar, Ø 3 mm
16	Load pin
17	DC jack
18	Data interface



Users should never change any other screws!

Installation

The weigh cells are available in various versions. If you have ordered special options, the weigh cells are equipped with the specified features at the factory.

Storage and Shipping Conditions

- Once the equipment has been removed from the packaging, it may lose accuracy if subjected to strong vibration.
- Do not expose the equipment to unnecessarily extreme temperatures, moisture, shocks, blows or vibration.
- It is a good idea to save the box and all parts of the packaging until you have successfully installed your equipment. Only the original packaging provides the best protection for shipment.
- Before packing your equipment, unplug all connected cables to prevent unnecessary damage.
- Gravitational acceleration $\cong 300 \text{ m/s}^2$
Do not expose the equipment to gravitational acceleration in excess of $\cong 300 \text{ m/s}^2$ (unless additional equipment is installed on the load receptor).

Incoming Inspection

The customer shall inspect the product and packaging immediately upon delivery for proper functioning, completeness and absence of defects. This is to be performed in an incoming inspection within 10 days of delivery of the product or service. The incoming inspection must take place before the equipment is installed. Any obvious defects, errors, or incorrect delivery must be reported in writing. Defects detected at a later date must be reported in writing immediately upon detection.

Be sure to perform the following as part of the incoming inspection:

- We recommend performing a repeatability test using an auxiliary draft shield to make sure the weigh cells were not damaged in transport. You can use the YAC01ED display and control unit or the CAS-Suite software as an aid for this test.

Equipment Supplied

- Weigh cell
- Electronics module
- Installation instructions (this document)
- Special accessories as listed on the bill of delivery or in accordance with any customer-specific agreement

Installation instructions

The equipment is designed to provide reliable results under normal ambient conditions. If you have any questions or difficulties when developing your weighing system, please contact the specialists at Sartorius. When designing and setting up your weighing system, please observe the following so that you will be able to work with added speed and accuracy:

- Avoid exposing the equipment to the effects of extremely high temperatures; for example, caused by other electronic components, heaters or direct sunlight.
- Protect the equipment from direct drafts that come from open windows or doors.
- Avoid exposing the equipment to excessive vibrations during weighing; for example, caused by motors or valves

- Protect the equipment from aggressive chemical vapors.
- Avoid extreme moisture.
Switch the system to the standby mode when not in use.
- Avoid the effects of magnetism.

△ Always calibrate/adjust the weigh cells after transport:

- WZA...-N, WZA224ND:
External calibration
- WZA...-NC: Internal calibration

- Equipment installed on the load receptor can interfere with weigh cell functions. The user accepts all liability for production release and the specifications of the entire equipment. The specifications attained by your system may differ from those listed in the "Specifications" Chapter.

Conditioning the equipment:
Moisture in the air can condense on the surface of a cold weighing instrument or other device whenever it is moved to a substantially warmer place. If you transfer the equipment to a warmer area, make sure to condition it for about 2 hours at room temperature, leaving it unplugged from AC power.

Connecting the Weigh Cell to the Electronics Module

- Plug the connecting cable into the socket on the electronics module and the male connector on the weigh cell

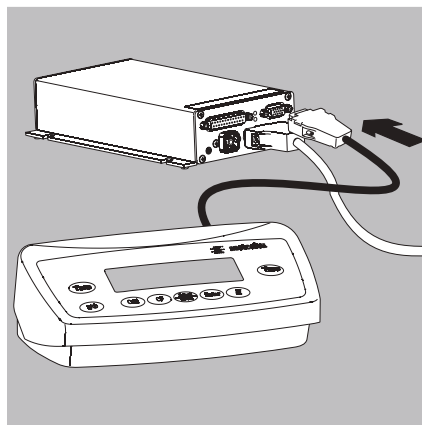
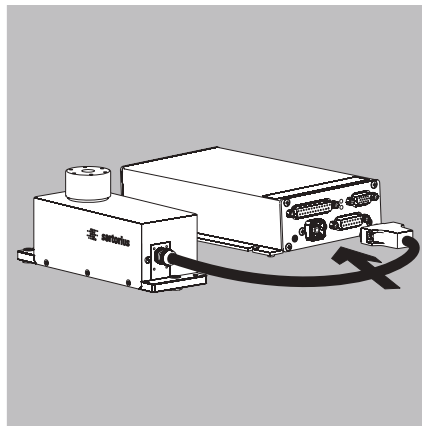

Connecting an Optional Display and Control Unit

- The YAC01ED display and control unit can be installed while operations are running (hot plug-in).
- Plug the cable into the socket on the electronics module.

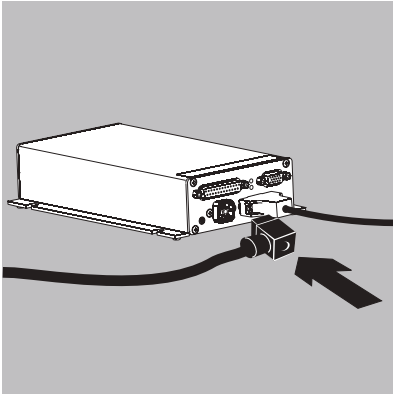

Connecting the Device to AC Power

- Check the voltage rating and the plug design
If they do not match your local rating or standard: contact your supplier
Use only
 - Genuine Sartorius AC adapters or power supplies
 - AC adapters approved by specialist technicians
- Insert the right-angle plug from the AC adapter into the jack on the electronics module and tighten the fastening screw
- Connect the equipment to power:
 - plug the AC adapter into the wall outlet (mains)
- > After connecting the power supply: the LED "RxD/Power" lights up yellow
- Power is supplied through the DC jack (Hirschmann plug).
If the stated supply voltage or the plug design of the power cord does not comply with your country's standard, please inform the nearest Sartorius representative or your dealer.
- Using an AC adapter other than that supplied with the equipment:
The device can be operated with a supply voltage of 12 V to max. 26 V.
- △ The power connection must be made in accordance with the regulations applicable in your country.

Safety requirements for operation of the evaluation electronics connected to a safety extra-low voltage (SELV) source:

The external power supply must meet the requirements of EN 61010-1, Section 6: Protection Against Shock Current. Please also refer to the specifications for classification of electrically operated equipment in EN 61010-1.

Safety Precautions:

The power supply must be rated to safety extra low voltage (SELV) or grounded (earthed) safety extra low voltage (SELV-E).

An AC adapter rated to Class 2 can be plugged into any wall outlet with no additional safety precautions required. A ground or earth terminal is connected to the housing. The electronics module must be grounded for operation. The data interface is also electrically connected (grounded) to the weigh cell housing.

EMC Requirements:

The connector is designed for DC connections between equipment/systems that are not connected to a DC power supply. The cable length must not exceed 3 m.

To use an external power supply, the power source must meet the requirements of EN 61326. The following standards apply:

Fast transients	IEC61000-4-4
Surge voltage	IEC 61000-4-5
Conductive HF signals	IEC61000-4-6

Socket, electronics unit	Type: G 4 A 5 M
Socket for the above connector	Type: G 4 W 1 F, Hirschmann order no. 932157-100

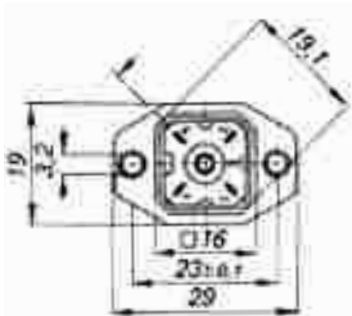

Dimensions in mm

Hirschmann Electronics GmbH & Co.
Stuttgarter Strasse 45-51
72654 Neckartenzlingen
Germany

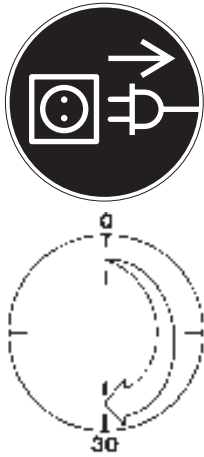

Connecting Electronic Peripheral Devices

- Make absolutely sure to unplug the weigh cell from AC power before you connect or disconnect a peripheral device (e.g., PC) to or from the interface port:

Warm-up Time

The amount of warm-up time required depends in part on the system used. To return precise results, the weigh cell must warm up for at least the length of time indicated below after it is connected to power for the first time:

- WZA224-N/WZA224-ND: 45 minutes
- Other WZA...-N/-NC-models: 30 minutes

Only after this time will the device have reached the required operating temperature.

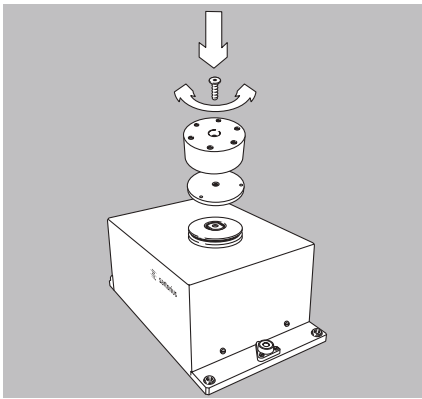

WZA8202-N/-NC: Installing Parts

- Position spacer and load receptor
- Tighten the (S1) screw supplied to fasten the load receptor:
For torque values, see table on the next page

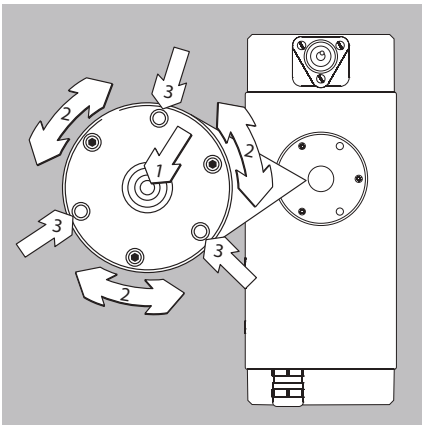

Leveling the Load Receptor and Attaching the User-specific Transducer

- Remove **(1)** screw
- Use the **(2)** screws to radially position and level the load receptor (minor height adjustment also possible)
- Attach the **(1)** screw to affix the load receptor:
For torque values, see table on the next page
- Attach any user-specific transducer to the threaded fastener **(3)** on the load receptor.
For torque values, see table on the next page:
Maximum permissible load on load receptor

⚠ Make sure the user-specific transducer is rigid, and is firmly attached to the load receptor.

Maximum permissible load on load receptor:

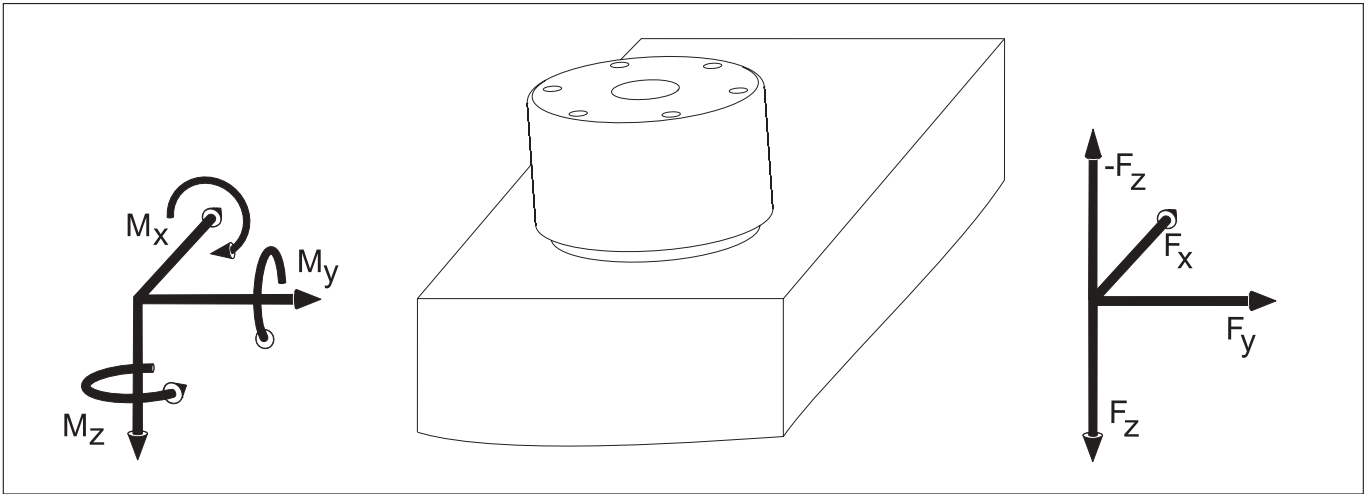

Model	Max. torque M_x, M_y, M_z	Screwing torque	Max. force opposite to direction of load ($-F_z$)	Max. forces F_x, F_y, F_z
WZA224-N WZA224-ND WZA224-NC	2 Nm	1 Nm	3 N	20 N
WZA523-N WZA523-NC	2.5 Nm	1 Nm	6 N	25 N
WZA1203-N WZA1203-NC	4 Nm	2 Nm	15 N	40 N
WZA8202-N WZA8202-NC	8 Nm	4 Nm	100 N	80 N F_z 200 N
WZA25-NC	0.1 Nm	0.5 Nm	2 N	2 N

Higher loads may result in damage to the weigh cell.

Example:

Weigh cell with hook projecting out to the front.
Torque M_y is the sum of the torque from the force of the weight W_{Load} , the torque of any excess weight being exerted W_{Ex} and the torque created by the intrinsic weight W_{Hook} holding the weight.

Example:

How heavy may the maximum off-center overload force F_{over} for a WZA224-N at a load of $M_{Load} = 100$ g and a hook arm length L of 100 mm and an intrinsic weight $M_{Hook} = 60$ g be?

$$M_{Load} = M_{Load} \times 9.81 \text{ m/s}^2 \times L$$

$$M_{Load} = 0.098 \text{ Nm}$$

$$M_{Hook} = M_{Hook} \times 9.81 \text{ m/s}^2 \times L / 2$$

$$M_{Hook} = 0.029 \text{ Nm}$$

$$M_{Ex} = F_{Ex} \times L$$

$$M_y = M_{Load} + M_{Hook} + M_{Ex}$$

$$W_{Ex} = (M_{corner} - M_{Load} - M_{Hook}) / L$$

$$W_{Ex} = 18.7 \text{ N}$$

However, even very small forces can trigger the overload protection mechanism.

In general, load receptors should be constructed to be rigid to bending and twisting. We recommend testing to avoid unwanted feedback effects in the control loop. You should also take into account the effects of drafts and observe all instructions for analytical weighing.

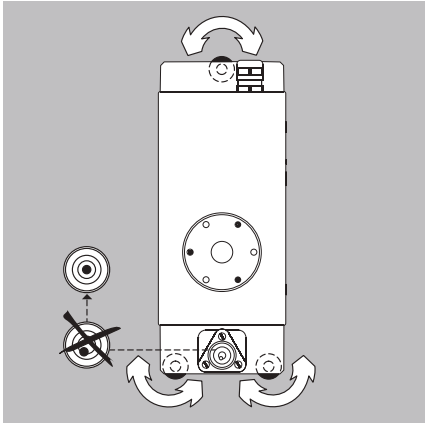

Leveling the Weigh Cell in a Portable Weighing System (Leveling Feet Optional)

Purpose:

- To compensate for uneven areas at the place of installation.
- To ensure that the weigh cell is placed in a perfectly horizontal position for consistently reproducible weighing results.
- Always level the weigh cell again any time after it has been moved to a different location.

- Adjust the leveling feet until the air bubble is centered within the circle on the level indicator.

Permanently Installed Weigh Cells

- Adjust the weigh cell after it has been installed in the system in its permanent location – see next page.
The weigh cell must be calibrated/adjusted again any time its location or position is changed.

- For optimum operation, install the weigh cell in a horizontal position.

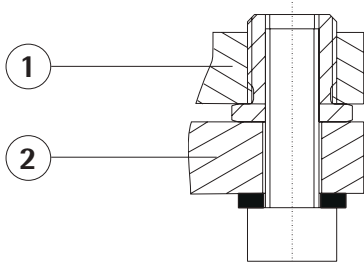

- 1) Bottom plate of the weigh cell

- 2) Fastening frame of the system

- Fastening with M6 screws:

Connection to the threaded fasteners on the weigh cell **(1)**: torque 2.5 Nm

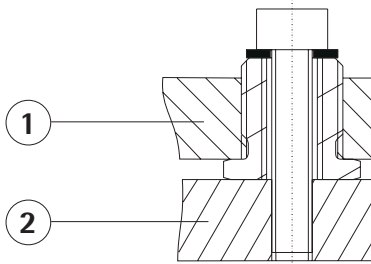

- Fastening with M4 screws:

Connection to the threaded fasteners of a user-specific frame **(2)**.

⚠ Do not unscrew the sleeve.

Operation

Notes on Analytical Weighing with Weigh Cells

Handling of Samples and Containers

Samples should be acclimatized to the temperature of the weigh cell. This is the only way to avoid negative effects on results, such as measurement errors and fluctuations caused by air buoyancy resulting from convection currents across the surface of the sample.

These negative effects increase as the volume and/or surface area of the sample increases. For this reason, the size of the container should be appropriate for the sample.

Samples and containers should not be touched by the operator's hands, as the hygroscopic effect of fingerprints and the effect of the hand's temperature can influence the measurement results.

Samples must be applied very carefully, whether manually (using a forceps) or automatically (by a robot or filling system).

When designing a draft shield device, steps must be taken to keep the increase in temperature within the weighing chamber to a minimum (e.g., using a bypass).

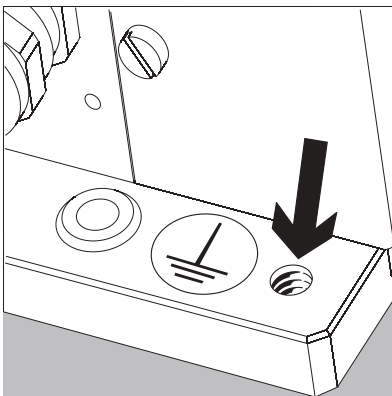

Weighing Electrostatically Charged Samples and Containers

Significant measuring errors can occur when electrostatically charged objects are weighed. Materials with extremely low conductivity, such as glass, plastic or filters, are particularly susceptible to static electricity (resulting e.g. from friction) because the weighing pan can discharge the static electricity only very slowly.

The result is a force action between the charge on the sample and the permanently installed parts of the weigh cell. This causes the readout to fluctuate constantly.

Ionization can be applied to make the air around the sample conductive. This allows the charge to be compensated through the air, or discharged through the ground (grounded).

Aside from purely mechanical solutions (e.g., using a special weighing pan to shield the sample), bombarding the sample with ions of opposing polarity to neutralize the surface charge is one of the most effective methods for eliminating static electricity. Sartorius can provide ionization devices for installation in weighing systems.

The area around the weigh cell, like plastic parts, can also contain charges that negatively affect the accuracy of weighing results. Appropriate steps (grounding) taken in the design of a draft shield device can counteract such effects.

A threaded hole (M6) in the equipotential bonding terminal is provided on the rear of the weighing cell mounting plate for grounding equipment (e.g., a scoop). It must be ensured that the frame is grounded.

Weighing Magnetic or Magnetizable Samples

It is technically impossible to avoid using magnetizable materials for the production of weigh cells. This is primarily because the operating principle of high-resolution weigh cells is based on compensation of the load through magnetic forces.

When weighing magnetic or magnetizable samples or containers, interaction between the sample or container and the above-mentioned parts inside the weigh cell may have a distorting effect on the weighing results.

To keep such effects to a minimum, we recommend increasing the distance between the sample/container and the weighing system using a non-magnetic material. The force is reduced quadratically with the increase in distance.

Magnetizable or magnetized samples and the weigh cell itself interact with magnetic fields and magnetizable or magnetized parts in the area surrounding the weighing system. The system can be shielded from external magnetic fields to some extent using (soft magnetic) plates.

Effects of Drafts

Depending on the size of the load receptor and the sample, the effects of drafts may occur.

To minimize this effect, install a draft shield for protection.

Calibration/Adjustment

Calibration/adjustment can be performed as follows:

- Using control commands sent by the CAS-Suite configuration software from Sartorius, installed on a computer (see page 23 for the commands)

or

- Using the optional YAC01ED control unit

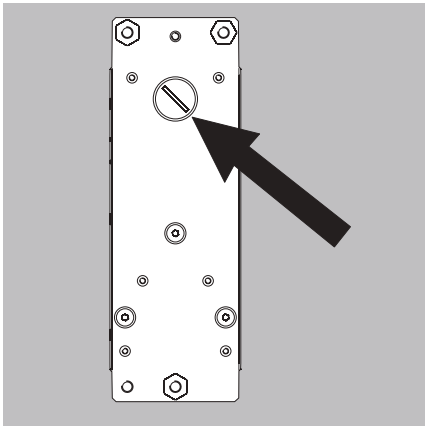

Below-Cell Weighing

A port for a below-cell weighing hanger is located on the bottom of the weigh cell (not on model WZA25-NC).

- Remove the closing screw.
- **Overload protection**
 - Standard feature on the following models: WZA224-N/-NC, WZA1203-N/-NC, WZA523-N/-NC
 - △ No overload protection provided on the following models: WZA8202-N/-NC, WZA25-NC

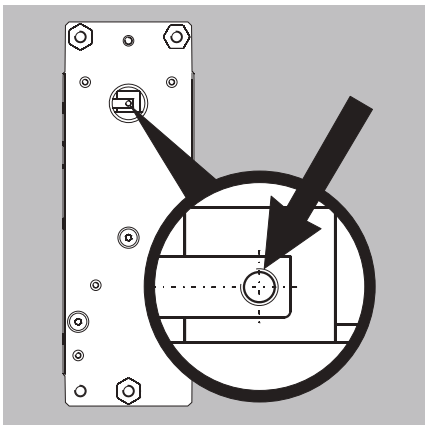

- Carefully install the customer-specific hook.
Threaded fastener for hook: M3
Maximum torque: 0.8 Nm.
- △ Maximum screw installation depth: do not exceed 5 mm!
- Install a draft shield if necessary

Operation with the Optional YAC01ED Display and Control Unit

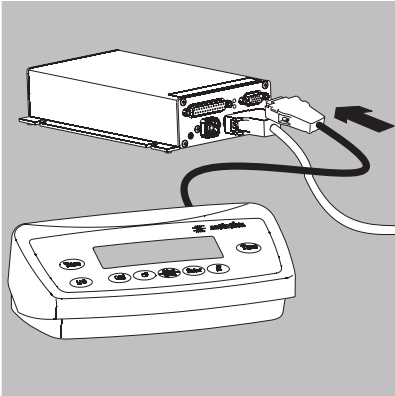

Connect display and control supplied to the weigh cell electronic unit using cable.

Connecting cable: Approx. 1 meter long with 15-pin D-Sub plug and socket. Pin 15 is not assigned.

Overview of Display and Operating Elements

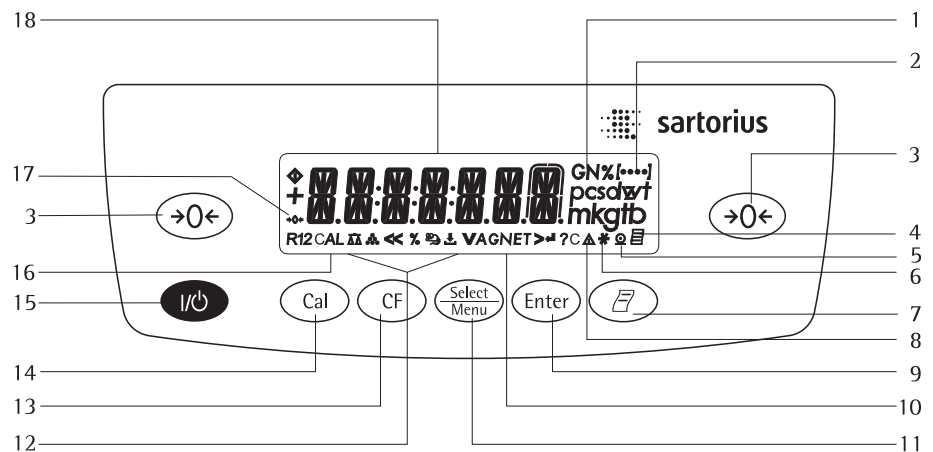

Position Designation

Position	Designation
1	Weight units
2	Menu level indicator
3	Tare Zero
4	Symbol "GLP printing mode active"
5	Symbol: "Printing mode active"
6	Application program active
7	Data output: Press this key to send readout values to the built-in data interface.
8	Calculated-value indicator: not a weight value
9	Start an application program
10	Display: Gross or net value
11	Select an application program Open the operating menu
12	Symbols for active application (Δ , \clubsuit , %, \downarrow , A, C)

Position Designation



Position	Designation
13	Clear Function This key is generally used to cancel functions: – Quit application program – Cancel calibration/adjustment routine Exit menu
14	Start the calibration process
15	On/off switch
16	Display: Calibration/adjustment function
17	Symbols for zero range (verified models only)
18	Weight value displayed in selected weight unit
Symbol:	
<<	Exit menu
<	One menu level higher
V	Scroll through menu items
>	To select the next sub-item within a group
\downarrow	To confirm the menu item selected

Basic weighing function

Features

- Taring the weigh cell
- Print weight value

Preparation





- Switch on the weigh cell:
Press the  key
- Tare the balance/scale, if necessary:
Press 
- If necessary, change the configuration settings:
see the chapter entitled "Configuration"
- If desired, load the factory settings:
see the chapter entitled "Configuration"

Additional Functions:

- Switching off the weigh cell:
Press 

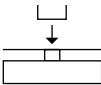
Example:

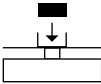
Determine a weight value

Step	Press key	Display/Printout
1. Switch on the weigh cell: Self-test runs followed by automatic initial tare function.		0.0 g
2. Place container on weighing pan (in this example 11.5 g).		+ 11.5 g
3. Tare the weigh cell		0.0 g
4. Place sample in container (in this example 4.66 oz).		+ 132.0 g
5. Print weight value		N + 132.0 g

Configuration (Operating Menu)

Purpose

The weigh cell is configured at the factory. In Setup, you can configure the weight cell, i.e. adapt it to individual requirements.

Features

The weighing parameters are combined into the following groups (menu level 1):

1. Weigh cell functions
 - Interface
 - Record (print)
 - Extra functions
2. Application programs
3. Input
4. Information
5. Language setting

Factory Settings for the Parameters

The factory-set configurations are identified by an "o" in the list below.

Customer-specific settings can be configured on request.

Preparation







- Using the CAS-Suite configuration software from Sartorius installed on a PC, you can process the operating menu parameters as follows:
 - Read
 - Edit
 - Print
 - Save

or

Using the optional YAC01ED control unit





Configuring of the weigh cell, i.e., adapting it to individual requirements.

Functions of the Keys in the Menu:

Symbol displayed	Key	Function
V		Set menu item
>		One menu level lower (with cursor right up to 4 menu levels)
↵		Confirm menu item
		Save settings and exit menu from any position
<<		Save settings and exit menu:
<		One menu level higher (left cursor)
[••••]		Indicates menu level

Menu Navigation

Example: Setting the language

Step	Press key	Display
1. Open the menu: In weighing mode: first menu item is shown	 hold	APPLIC.
2. Scroll upward within the menu level; After the last menu code, the first code is displayed again (scroll)	Repeatedly press 	INPUT ... LANGUAG.
3. Select next menu level (scrolls to the right)	Repeatedly press 	ENGLISH °
5. Change setting: Select the menu item by scrolling up		GERMAN
6. Confirm setting; “o” indicates the active Menu item		GERMAN °
7. Go back to the previous menu level (from menu level 4)		LANGUAG
○ If required, select further menu items	 , 	
8. Save settings and exit menu:	Repeatedly press 	
or		
○ Exit menu without saving changes		
> Restart your application		0.0 g

Menu Structure (Overview)

Level 1 [●]	Level 2 [●●]	Level 3 [●●●]	Codes	
SETUP	BAL.SCAL. (Weigh cell functions)	AMBIENT Ambient conditions (Adapt filter)	1. 1. 1.	
		APP.FILT. Application filter	1. 1. 2.	
		STAB.RNG. Stability range	1. 1. 3.	
		ST.DEL. Stability delay	1. 1. 4.	
		TARING Taring	1. 1. 5.	
		AUTOZER. Auto zero	1. 1. 6.	
		WT.UNIT Basic weight unit	1. 1. 7.	
		DISPLAY Display accuracy	1. 1. 8.	
		CAL./ADJ. Function of the  key	1. 1. 9.	
		CAL.ROUTINE	1. 1.10.	
		CAL.UNIT Weight unit for calibration	1. 1.11.	
		ZERO.RNG. Zero range	1. 1.12.	
		ZERO.ON Zero at Power On	1. 1.13.	
		ON.TARE Tare/zero at power:	1. 1.14.	
		INTERF. Interface	BAUD Baudrate	1. 5. 1.
	PARITY Parity		1. 5. 2.	
	STOP BIT Number of stop bits		1. 5. 3.	
	HANDBSHK. Handshake mode		1. 5. 4.	
	DATA BIT Number of data bits		1. 5. 5.	
	BAT.PROT. SBI (ASCII) or printout		1. 5. 6.	
	BAT.REC. (Print)	PRINT (manual/automatic)	1. 6. 1.	
		STOP automatic printing	1. 6. 2.	
		AUT.CYCL. Time-dependent autom. printing	1. 6. 3.	
		TAR./PRT. Tare bal./scale after ind. print	1. 6. 4.	
		PRT.INIT. Printout of appl. parameters	1. 6. 5.	
		FORMAT Line format for printout	1. 6. 6.	
		GLP ISO/GLP-compliant printout	1. 6. 7.	
		TIME 12h/24h	1. 6. 8.	
		BATE format	1. 6. 9.	
	EXTRAS (Additional functions)	MENU Can Edit / Can change settings	1. 8. 1.	
		HORN Acoustic Signal	1. 8. 2.	
		KEYS (Keypad)	1. 8. 3.	
		EXT.KEY External switch function	1. 8. 4.	
		ON.MODE Power-on mode	1. 8. 5.	
		BACKLIT Display backlighting	1. 8. 6.	
	RESET	MENU Factory settings	1. 9. 1.	
	APPLIC. Application programs	WEIGH		2. 1.
		UNIT Toggle	DISPLAY Display accuracy	2. 2. 2.
		COUNTING	RESOLUT.	2. 3. 1.
			REF.UPDT. Auto reference updating	2. 3. 2.
		PERCENT weighing	DEC.PLCS Decimal places	2. 4. 1.
NET.TOT. Net total		COMP.PRT. Printout of components	2. 5. 1.	
TOTAL Totalizing		COMP.PRT. Printout of components	2. 6. 1.	
ANIMALW. Animal weighing		ACTIVITY. Animal activity	2. 7. 1.	
		START	2. 7. 2.	
CALC. Calculation		METHOD (Operator)	2. 8. 1.	
		DEC.PLCS Decimal places	2. 8. 2.	
DENSITY determination	DEC.PLCS Decimal places	2. 9. 1.		
INPUT Input	ID NO.	ID input; max. 7 characters	3. 1.	
INFO Information	VERSION, SER. NO., MODEL	Displays software vers., serial no., model	4. 1./2./3.	
LANGUAGE (LANGUAGE.)	ENGLISH (factory setting)		5. 1.	
	DEUTSCH (German)		5. 2.	
	FRANC. (French)		5. 3.	
	ITAL. (Italian)		5. 4.	
	ESPAÑOL (Spanish)		5. 5.	
	PYCEK (Russian)		5. 6.	
	POLSKI (Polish)		5. 7.	
	CODES Menu shows codes (not texts)		5. 8.	







Parameter settings: Overview

o = Factory setting; ✓ = User-defined setting

Level 1 [•]	Level 2 [••]	Level 3 [•••]	Level 4 [••••]	Code
1.) SETUP	BAL.SCAL Weigh cell functions	AMBIENT conditions (Filter adaptation)	o V.STABLE Very stable conditions	1. 1. 1. 1
			o STABLE Stable conditions	1. 1. 1. 2
			o UNSTABL Stable conditions	1. 1. 1. 3
			o V.UNSTBL. Very unstable conditions	1. 1. 1. 4
		APP.FILT. Application filter	o FINAL.RD. Final readout mode	1. 1. 2. 1
			FILLING Filling mode	1. 1. 2. 2
		STAB.RNG. Stability range	1/4 DIG. (digit)	1. 1. 3. 1
			1/2 DIG. (digit)	1. 1. 3. 2
			1 DIG. (digit)	1. 1. 3. 3
			2-DIG. (digit)	1. 1. 3. 4
			4 DIG. (digit)	1. 1. 3. 5
			o 8 DIG. (digit)	1. 1. 3. 6
		STAB.delay	No delay	1. 1. 4. 1
			o Short delay	1. 1. 4. 2
			Medium delay	1. 1. 4. 3
			Long delay	1. 1. 4. 4
		TARING Taring	o W/O STB W/o stability	1. 1. 5. 1
			o W/ STAB After stability	1. 1. 5. 2
		AUT.ZERO Auto zero	o OFF	1. 1. 6. 1
			o ON	1. 1. 6. 2
		WT.UNIT Basic Weight unit	For list of units, Gram to Newton	1. 1. 7. 1 to 1. 1. 7.23
			DISPLAY Basic accuracy	o ALL
		MINUS 1 One level lower		1. 1. 8. 2
		Increment of the measured values one level lower		1. 1. 8. 3
		Increment of the measured values two levels lower		1. 1. 8. 4
		Increment of the measured values three levels lower		1. 1. 8. 5
		o INCRM. 1 Last digit single increment resolution by a factor of 10		1. 1. 8. 6 1. 1. 8. 8
		CAL./ADJ. Function of the (Cal) key	o CAL.EXT. Adjustment/calibration with factory-set weight	1. 1. 9. 1
			o E.CAL.USR. External calibration/adjustment with user-defined weights (factory-set on WZA25-NC)	1. 1. 9. 3
			o CAL.INT. Internal calibration/adjustment only on models WZA...-NC	1. 1. 9. 4
			o LINE.EXT. Linearization with factory-set weights	1. 1. 9. 6
			o LINE.USR. Linearization with user-def. weights	1. 1. 9. 7
o STR.PREL. Set preload	1. 1. 9. 8			
o CLR.PRELOAD Clear preload	1. 1. 9. 9			
o BLOCKED (Cal) Blocked	1. 1. 9. 11			
o ADJ. one sequence	1. 1. 10. 1			
o CAL./ADJ. as required	1. 1. 10. 2			
CAL.UNIT Weight unit for calibration	o GRAMS		1. 1. 11. 1	
	o KILOGR. Kilograms	1. 1. 11. 2		
	o POUNDS	1. 1. 11. 3		
ZERO.RNG. Zero range	DEFAULT. (factory-set)	1. 1. 12. 1		
	o 2 PERC.ent	1. 1. 12. 2		
	o 5 PERC.ent	1. 1. 12. 3		
	o 10 PERC.ent	1. 1. 12. 4		
INT.ZERO Power On	Zero at power-on default (factory-set)	1. 1. 13. 1		
	Initial zero 2%/max. cap	1. 1. 13. 2		
	o Initial zero 5%/max. cap	1. 1. 13. 3		
	Initial zero 10%/max. cap	1. 1. 13. 4		
	Initial zero 20%/max. cap	1. 1. 13. 5		
	Initial zero 50%/max. cap	1. 1. 13. 6		
	Initial zero 100%/max. cap	1. 1. 13. 7		
ON.TARE (Tare/Zero at Power/Zero-setting range)	o ON	1. 1. 14. 1		
	o OFF	1. 1. 14. 2		

Level 1 [•]	Level 2 [••]	Level 3 [•••]	Level 4 [••••]	Code
SETUP	INTERF. Interface	BAUDrate	600	1. 5. 1. 3
			<input type="radio"/> 1200	1. 5. 1. 4
2400			1. 5. 1. 5	
4800			1. 5. 1. 6	
9600			1. 5. 1. 7	
19200			1. 5. 1. 8	
<input type="radio"/> 38400 (factory-set on WZA224-ND)			1. 5. 1. 9	
PARITY Parity			<input type="radio"/> ODD	1. 5. 2. 3
			EVEN	1. 5. 2. 4
		NONE	1. 5. 2. 5	
STOP BIT Number of stop bits		<input type="radio"/> 1 STOP	1. 5. 3. 1	
		2 STOP	1. 5. 3. 2	
HANDSHK. Handshake mode		SOFTW. Software	1. 5. 4. 1	
		<input type="radio"/> HARDW. Hardware	1. 5. 4. 2	
	NONE	1. 5. 4. 3		
DATA BIT Number of data bits	<input type="radio"/> 7 BITS	1. 5. 5. 1		
	8 BITS	1. 5. 5. 2		
DAT.REC. Com- munication mode	<input type="radio"/> SBI (ASCII ¹⁾)	1. 5. 6. 1		
	PRINTER (GLP-compliant record)	1. 5. 6. 2		
	XBPI	1. 5. 6. 4		
DAT.REC. (Printout)	PRINT (manual/ automatic)	MANUAL WITHOUT stability	1. 6. 1. 1	
		<input type="radio"/> MAN.WITH. stability	1. 6. 1. 2	
		AUTO.W/O. stability	1. 6. 1. 3	
		AUT.WITH stability	1. 6. 1. 4	
		LD.CHNGE Autom. after load change	1. 6. 1. 5	
	STOP auto- matic printing	<input type="radio"/> OFF Not possible	1. 6. 2. 1	
		ON Cancel with 	1. 6. 2. 2	
	AUT.CYCL. Time-dependent autom. printing	<input type="radio"/> EACHVAL (1 display update)	1. 6. 3. 1	
		AFTER 2 (2 display updates)	1. 6. 3. 2	
	TAR./PRT. Tare bal./scale after ind. print	<input type="radio"/> OFF	1. 6. 4. 1	
		ON	1. 6. 4. 2	

¹⁾ Note concerning verified balances/scales as legal measuring instruments in the EU*:
 In the setting "SBI", the non-verified display digit is not automatically identified.
 Please take the corresponding measures or adjust the settings on the peripheral device.

Level 1 [•]	Level 2 [••]	Level 3 [•••]	Level 4 [••••]	Code
SETUP	DAT.REC. (Printout)	PRT.INIT.	o OFF	1. 6. 5. 1
		Printing appli- cation parameters	ALL All parameters MAINPAR. Main parameters	1. 6. 5. 2 1. 6. 5. 3
FORMAT Line format for printout		o 16.CHAR. 16 characters (w/o ID)	1. 6. 6. 1	
		22.CHAR. 22 characters (w/ ID)	1. 6. 6. 2	
		2NDLINE with date/time	1. 6. 6. 3	
GLP ISO/GLP- compliant printout		o OFF	1. 6. 7. 1	
		CAL.-ADJ. Only for calib./adj.	1. 6. 7. 2	
		ALWAYS on	1. 6. 7. 3	
TIME		o 24H 24-hour format	1. 6. 8. 1	
		12H 12-hour format "AM/PM"	1. 6. 8. 2	
DATE	o DD.MM.YY Day/month/year	1. 6. 9. 1		
	MM.DD.YY Month/day/year	1. 6. 9. 2		
EXTRAS (Additional functions)	MENU	o CANEDIT	1. 8. 1. 1	
		RD.ONLY Read only	1. 8. 1. 2	
	HORN Acoustic Signal	OFF	1. 8. 2. 1	
		o ON	1. 8. 2. 2	
	KEYS (Keypad)	o FREE	1. 8. 3. 1	
		LOCKED	1. 8. 3. 2	
	EXT.KEY. Function of the external switch	o PRINT key 	1. 8. 4. 1	
		Z/TARE 	1. 8. 4. 2	
		CAL. 	1. 8. 4. 3	
		SELECT 	1. 8. 4. 4	
CF 		1. 8. 4. 5		
ENTER 		1. 8. 4. 6		
ON MODE Power-on mode	OFF/ON Off/on/standby	1. 8. 4. 9		
	STANDBY On/standby	1. 8. 5. 1 1. 8. 5. 2		
	o AUTON Auto on	1. 8. 5. 3		
BACKLIT Display backlighting	OFF	1. 8. 6. 1		
	o ON	1. 8. 6. 2		
RESET Reset menu	MENU Factory settings	YES Restore factory settings	1. 9. 1. 1	
		o NO Do not restore settings	1. 9. 1. 2	

Level 1 [•]	Level 2 [••]	Level 3 [•••]	Level 4 [••••]	Code	
APPLIC. Applic. programs 1)	WEIGH			2. 1.	
	UNIT Toggle units	DISPLAY Display accuracy	<input type="radio"/> ALL <input type="radio"/> MINUS 1 One level lower <input type="radio"/> Increment of the measured values one level lower <input type="radio"/> Increment of the measured values two levels lower <input type="radio"/> Increment of the measured values three levels lower <input type="radio"/> INCRM. 1 Last digit single increment <input type="radio"/> resolution by a factor of 10	2. 2. 2. 1 2. 2. 2. 2 2. 2. 2. 3 2. 2. 2. 4 2. 2. 2. 5 2. 2. 2. 6 2. 2. 2. 8	
	COUNTING	RESOLUT.		<input type="radio"/> DISP.DIG. Display accuracy <input type="radio"/> 10 FOLD 10 times > disp.	2. 3. 1. 1 2. 3. 1. 2
		REF.UPDT. Auto Reference updating		<input type="radio"/> OFF <input type="radio"/> AUTOM.	2. 3. 2. 1 2. 3. 2. 2
	PERCENT Weighing in percent	DEC.PLCS. Decimal places		<input type="radio"/> NONE No dec. places	2. 4. 1. 1
				<input type="radio"/> 1 DEC.PL. 1 decimal place	2. 4. 1. 2
				<input type="radio"/> 2 DEC.PL. 2 decimal places <input type="radio"/> 3 DEC.PL. 3 decimal places	2. 4. 1. 3 2. 4. 1. 4
	NET.TOT. Net total	COMP.PRT. Component printout		<input type="radio"/> OFF	2. 5. 1. 1
				<input type="radio"/> ON	2. 5. 1. 2
	TOTAL Totalizing	COMP.PRT. Component printout		<input type="radio"/> OFF	2. 6. 1. 1
				<input type="radio"/> ON	2. 6. 1. 2
	ANIMALW. Animal weighing	ACTIVITY. Animal activity		<input type="radio"/> CALM (fluct.: 2% of test obj.)	2. 7. 1. 1
				<input type="radio"/> ACTIVE (fluct.: 5% of test obj.)	2. 7. 1. 2
				<input type="radio"/> V.ACTIVE (fluct.: 20% of test obj.)	2. 7. 1. 3
		START		<input type="radio"/> MANUAL	2. 7. 2. 1
				<input type="radio"/> AUTO. Automatic	2. 7. 2. 2
	CALC. Calculation	METHOD (operator)		<input type="radio"/> MUL. Multiplier	2. 8. 1. 1
				<input type="radio"/> DIV. Divisor	2. 8. 1. 2
		DEC.PLCS Decimal places		<input type="radio"/> NONE No dec. places	2. 8. 2. 1
			<input type="radio"/> 1 DEC.PL. 1 decimal place	2. 8. 2. 2	
			<input type="radio"/> 2 DEC.PL. 2 decimal places <input type="radio"/> 3 DEC.PL. 3 decimal places	2. 8. 2. 3 2. 8. 2. 4	
	DENSITY determination	DEC.PLCS Decimal places		<input type="radio"/> NONE No dec. places	2. 9. 1. 1
			<input type="radio"/> 1 DEC.PL. 1 decimal place	2. 9. 1. 2	

1) If you need more detailed information on application programs:
Please contact your local Sartorius dealer.

Configuration (Setup)

Purpose

The weigh cells are equipped with an interface port for connection to a computer or other peripheral device.

PC

You can connect a computer to change, start and/or monitor functions and application programs.

Features

Type of interface: Serial interface

Interface operating mode: Full duplex

Level: RS-232

Transmission rate:

600, 1200, 2400, 4800, 9600, 19,200 and 38,400 baud

Parity: Odd, even, none

Number of data bits: 7 or 8 bits

Character transmission:

Start bit, 7-bit ASCII, parity, 1 or 2 stop bits

Handshake:

For 2-wire interface:

Software (XON/XOFF) or none

For 4-wire interface:

Hardware (CTS/DTR) or none

Data output of balance:

16 or 22 characters

Factory Setting of the Parameters

Transmission rate:

1200 baud (Code 1. 5. 1. 4)

Parity: 000 Odd (1. 5. 2. 3)

Stop bits: 15TOPbit (1. 5. 3. 1)

Handshake:

HANDSK. Hardware handshake (1. 5. 4. 2)

Communication mode: SBI (1. 5. 6. 1)

Printing: MAN.WITH Manual after stability (1. 6. 1. 2)

Preparation

See "Pin Assignments" and "Pin Assignment Chart"

Operation

Output Format with 16 Characters (Compatibility with Current Weigh Cells)

Display segments that are not activated are output as spaces.

The type of character that can be output depends on the character's position:

Position	1	2	3	4	5	6	7	8	9	10	11	12	13	14	15	16
	+			A	A	A	A	A	A	A	*	E	E	E	CR	LF
or	-				*	*	*		
or	*		*	*	*	*	*	*	*	*						

*: Spaces

A: Displayed characters

E: Unit symbol

CR: Carriage return

LF: Line feed

.: Decimal point

Special Codes

Position	1	2	3	4	5	6	7	8	9	10	11	12	13	14	15	16
	*	*	*	*	*	*	*	*	*	*	*	*	*	*	CR	LF
or							H	i	g	h						
or							L	o	w							
or				C	a	l	.	E	x	t	.					

*: Spaces

Cal. Ext. Calibration, external

High: Overload

Low: Underload

Error message

Position	1	2	3	4	5	6	7	8	9	10	11	12	13	14	15	16
				E	r	r	*	#	#	#	*	*	*	*	CR	LF
				A	P	P	.	E	R	R ¹⁾	*	*	*	*	CR	LF
				D	l	S	.	E	R	R ¹⁾	*	*	*	*	CR	LF
				P	R	T	.	E	R	R ¹⁾	*	*	*	*	CR	LF

*: Spaces

#: Error code number

¹⁾ For cause and solution, please refer to the "Troubleshooting Guide"

Example: Output of the weight value + 123.56 g

Position	1	2	3	4	5	6	7	8	9	10	11	12	13	14	15	16
	+	*	*	*	1	2	3	.	5	6	*	g	*	*	CR	LF
	+	*	*	1	2	3	.	5	[6]¹)	g	*	*	CR	LF

- Position 1: Plus or minus sign or space
- Position 2: Spaces
- Position 3 - 10: Weight value with decimal point, leading zeros are output as spaces.
- Position 11: Spaces
- Position 12-14: Characters for unit of measure or space
- Position 15: Carriage return
- Position 16: Line feed

Output Format with 22 Characters (Compatibility with Current Weigh Cells)

When data is output with an ID code, the 6-character code precedes the 16-character string described above. These six characters identify the subsequent value.

1	2	3	4	5	6	7	8	9	10	11	12	13	14	15	16	17	18	19	20	21	22
K	K	K	K	K	K	+	*	A	A	A	A	A	A	A	A	*	E	E	E	CR	LF
	*	*	*	*	*	-	*	*	*			
						*	*	*	*	*	*	*	*	*	*						

- K: ID code character
- *: Spaces
- A: Displayed characters
- E: Unit symbol
- CR: Carriage return
- LF: Line feed

Example:

1	2	3	4	5	6	7	8	9	10	11	12	13	14	15	16	17	18	19	20	21	22	
N						+				1	2	3	.	5	6	*	g	*	*	CR	LF	
N						+				1	2	3	.	5	[6]¹)	g	*	*	CR	LF

SBI Mode:

When the SBI mode is active (menu code 1. 5. 6. 1), non-verified digits are not marked. Please take the corresponding measures or adjust the settings on the peripheral device.

Special Codes

1	2	3	4	5	6	7	8	9	10	11	12	13	14	15	16	17	18	19	20	21	22	
S	t	a	t	*	*	*	*	*	*	*	*	*	*	*	*	*	*	*	*	*	CR	LF
											H	i	g	h								
											L	o	w									
											C	a	l	.	E	x	t	.				

- *: Spaces
- Cal. Ext. Calibration, external
- High: Overload
- Low: Underload

Error message

1	2	3	4	5	6	7	8	9	10	11	12	13	14	15	16	17	18	19	20	21	22
S	t	a	t	*	*	*	*	*	E	R	R	*	#	#	#	*	*	*	*	CR	LF
S	t	a	t	*	*	*	*	*	A	P	P	.	E	R	R¹)	*	*	*	*	CR	LF
S	t	a	t	*	*	*	*	*	D	I	S	.	E	R	R¹)	*	*	*	*	CR	LF
S	t	a	t	*	*	*	*	*	P	R	T	.	E	R	R¹)	*	*	*	*	CR	LF

- *: Spaces
- # # #: Error code number

¹) For cause and solution, please refer to the "Troubleshooting Guide"

Commands (Data Input Format Compatible with Current Weigh Cells)



The computer connected via the data port can send commands to the weigh cell for controlling functions. The commands sent are control commands and may have different formats. Control commands consist of up to 13 characters. Each character must be transmitted according to the settings configured in the operating menu for data transmission.





Formats for Control Commands

Format 1:	Esc	!	CR	LF		
Format 2:	Esc	!	#	_	CR	LF

Esc: Escape (optional)
 !: Command character
 _: Underline

CR: Carriage return
 LF: Line feed (optional)

Command character	Format 1:	Meaning
!		
K		Ambient conditions: Very stable
L		Ambient conditions: calm
M		Ambient conditions: unstable
N		Ambient conditions: Very unstable
O		Block keys
P		 key (print, auto print; activate or block!)
Q		Acoustic signal
R		Unblock keys
S		Restart/self-test
T		Tare:  key
U		Tare
V		Zero
W		Calibrate Adjust depending on menu setting
Z		Perform internal calibration/adjustment ²⁾

Command character	Format 2:	Meaning
!#		
f0_		Function key 
f1_		function key  Calibration/adjustment (depending on the menu setting)
f2_		Function key 
s1_		With »s8_« compatibility: Toggle selection in steps of 1 With »s9_« compatibility: Adjust according to menu setting
s2_		Activate parameter mode (selection)
s3_		 key
s8_		Compatibility: Consistent with current weigh cells (from 2013)
s9_		Compatibility: Consistent with older weigh cells (previous models)
x0_		Perform internal adjustment
x1_		Print model
x2_		Print serial no.
x3_		Print software version

¹⁾ When initiating the print command, the data output rates may differ: see table on next page.

²⁾ only on models with built-in motorized calibration weight

Data Interface Port: Compatibility with Older Weigh Cells (Previous Models)

Once command »ESC s9_« has been sent, data input and data output behave as in the earlier Sartorius WZ-/WZA weigh cells (previous models).

Data Output Format

In operating mode »SBI«, 16 characters are printed out.

Example:

+ 253 pcs

Data Output Format with 16 Characters

Characters that are displayed blank are printed as spaces. Display values without a decimal point are output without a decimal point.

The type of character that can be output depends on the character's position:

Normal Operation

Position	1	2	3	4	5	6	7	8	9	10	11	12	13	14	15	16
	+	A	A	A	A	A	A	A	A	A	*	E	E	E	CR	LF
or	-		*	*	*		
or	*	*	*	*	*	*	*	*	*	*						

*: Space
 A: Digits of measurement value
 E: Unit symbol
 CR: Carriage return
 LF: Line feed

Sonderbetrieb

Position	1	2	3	4	5	6	7	8	9	10	11	12	13	14	15	16
	*	*	*	*	*	*	-	-	*	*	*	*	*	*	CR	LF
oder							H	H								
oder							L	L								
oder							C									

- *: Leerzeichen
- -: Auswaage
- H: Überlast
- H H: Überlast Kontrollwaage
(Funktion steht nur bei Betrieb mit folgender Peripherie zu Verfügung:
Optionale Anzeigeeinheit oder Software YAD011S)
- L: Unterlast
- L L: Unterlast Kontrollwaage
- C: Justieren

Fehlermeldung

Position	1	2	3	4	5	6	7	8	9	10	11	12	13	14	15	16
	*	*	*	E	r	r	*	#	#	#	*	*	*	*	CR	LF

- *: Leerzeichen
- # # #: Fehlernummer

Beispiel: Ausgabe des Wägewertes + 1255,7 g

Position	1	2	3	4	5	6	7	8	9	10	11	12	13	14	15	16
	+	*	*	*	1	2	5	5	.	7	*	g	*	*	CR	LF

- Position 1: Vorzeichen +, - oder Leerzeichen
- Position 2: Leerzeichen
- Position 3 - 10: Gewichtswert mit Dezimalpunkt, führende Nullen werden als Leerzeichen ausgegeben
- Position 11: Leerzeichen
- Position 12 - 14: Zeichen für Messeinheit oder Leerzeichen
- Position 15: Carriage Return
- Position 16: Line Feed

Dateneingangsformat

Ein über die Datenschnittstelle angeschlossener Rechner kann Befehle zum Gerät senden, um Gerätefunktionen zu steuern.

Diese Befehle sind Steuerbefehle und können unterschiedliche Formate haben. Steuerbefehle haben bis zu 26 Zeichen. Jedes dieser Zeichen muss den Setup-Einstellungen für die Datenübertragung entsprechend gesendet werden.

Formate für Steuerbefehle

Format 1:	Esc	!	CR	LF		
Format 2:	Esc	!	#	_	CR	LF

- Esc: Escape
- #: Ziffer
- _: Unterstrich (ASCII: 95)
- CR: Carriage Return (optional)
- LF: Line Feed (optional)
- max: abhängig vom Befehlszeichen, d.h. Parameter: Eingabe wird nach maximaler Länge abgeschnitten, nicht wie bei Eingabe über Tastatur verworfen
- !: Befehlszeichen

Format 1 (z.B.: ESC K)

!	Bedeutung
K	Filteranpassung: Sehr ruhige Umgebung
L	Filteranpassung: Ruhige Umgebung
M	Filteranpassung: Unruhige Umgebung
N	Filteranpassung: Sehr unruhige Umgebung
O	Tastatur sperren
Q	Akustisches Signal (Beep)
P	Print
R	Tastatur freigeben
S	Neustart
T	Tarieren und Nullstellen
Z	Internes Justieren

Format 2 (z.B.: ESC f3_)

!#	Bedeutung
f1_	Kalibrieren oder Justieren entsprechend Menüeinstellung
f3_	Nullstellen (Zero)
f4_	Tarieren (ohne Nullstellen)
s1_	Externes Justieren
s3_	Funktion [CF]
x0_	Kalibrieren intern ausführen
x1_	Print Wägezellentyp
x2_	Print Serien-Nr. Wägezelle
x3_	Software-Version Wägezelle

Synchronization

During data communication between the weigh cell and a connected device (computer), messages consisting of ASCII characters are transmitted via the interface. For error-free data exchange, parameters for baud rate, parity, handshake mode and character format must be identical for both units.

You can set these parameters in the Setup menu so that they match those of the connected device. You can also define parameters in the balance/scale to make data output dependent on various conditions. These conditions are described under each of the application program descriptions.

No errors are generated just because no peripheral device is connected to an interface port (open data port).

Handshake

The weigh cell interface (Sartorius Balance Interface = SBI) has transmit and receive buffers. You can define the different handshake parameters in the Setup menu of your weigh cell:

- Hardware handshake (CTS/DTR)
- Software handshake (XON, XOFF)
- No handshake

Hardware handshake

With a 4-wire interface, 1 more character can be transmitted after CTS (Clear to Send).

Software handshake

The software handshake is controlled via XON and XOFF. When a device is switched on, XON must be transmitted to enable any connected device to communicate.

Data Output by Print Command

The print command can be transmitted by pressing  or by a software command (Esc P).

Automatic Data Output

Activate the "auto print" operating mode to have data output to the interface port without a print command. You can have synchronized data output automatically at defined display update intervals, with or without the stability parameter. The length of a print interval depends on the operating menu settings for *AMBIENT* (ambient conditions) (menu code 1. 1. 1. x) and *AUT. CYCL.* (time-dependent autom. printing; menu code 1. 6. 3. x).

If you activate the auto print setting, data will be transmitted immediately the moment you turn on the balance/scale. In the operating menu, you can define whether automatic printing can be stopped by pressing the "Print" key or using the interface.

Data Output Rates – Values per Second

Ambient conditions (Filter adaptation)	WZA... XBPI	N/-NC SBI "Auto print"	WZA224-ND XBPI	WZA224-ND SBI "Auto print"
Very stable (1.1.1.1)	20	20	150	150
Stable (1.1.1.2)	10	10	150	150
Unstable (1.1.1.3)	5	5	150	150
Very unstable (1.1.1.4)	2.5	2.5	18.75	18.75

Pin Assignment Chart

Female Interface Connector:

25-contact D-Submini (DB25S) with screw lock hardware

Required Male Connector (Recommendation):

25-contact D-Submini (DB25S) with integrated shielded cable clamp assembly (Amp 826 985-1C) and fastening screws (Amp 164 868-1)

⚠ Warning When Using Pre-wired RS-232 Connecting Cables:

The pin assignments in RS-232 cables purchased from other manufacturers may be incompatible with Sartorius weighing instruments. Be sure to check the pin assignments against the chart below before connecting the cable, and disconnect any lines identified differently from those specified by Sartorius (e.g., pin 6).

Failure to do so may cause malfunction, damage or even completely ruin your balance/scale and/or peripheral device(s).

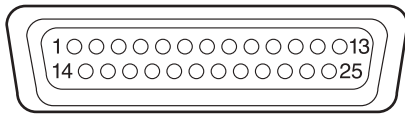

Pin Assignments:

Pin 1:	Signal Ground
Pin 2:	Data Output (TxD)
Pin 3:	Data Input (RxD)
Pin 4:	Internal Ground (GND)
Pin 5:	Clear to Send (CTS)
Pin 6:	Not Connected
Pin 7:	Internal Ground (GND)
Pin 8:	Internal Ground (GND)
Pin 9:	Not Connected
Pin 10:	Not Connected
Pin 11:	+12 V (Power supply for Sartorius printer)
Pin 12:	Reset _ Out ¹⁾
Pin 13:	+5 V
Pin 14:	Internal ground (GND)
Pin 15:	Universal remote switch
Pin 16:	Not Connected
Pin 17:	Not Connected
Pin 18:	Not Connected
Pin 19:	Not Connected
Pin 20:	Data Terminal Ready (DTR)
Pin 21:	Not Connected
Pin 22:	Not Connected
Pin 23:	Not Connected
Pin 24:	Not Connected
Pin 25:	+5 V

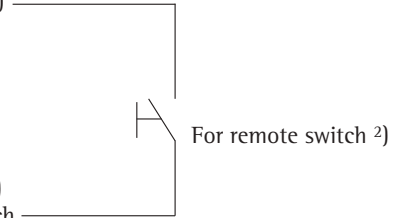

¹⁾ = Hardware restart

²⁾ = External switch function can be programmed in the menu Setup: *EXTTRAB* : *EXT*.key (1.8.4.x)

Cabling Diagram

For connecting a computer or other peripheral device to the balance/scale using the RS-232C/V24 protocol and cable lengths of up to 15 m (approx. 50 ft).

Do not connect any other pins to the cable connector of the balance/scale!

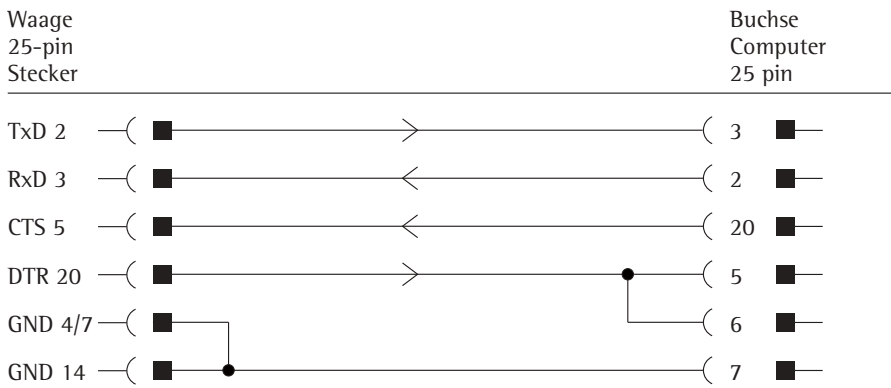
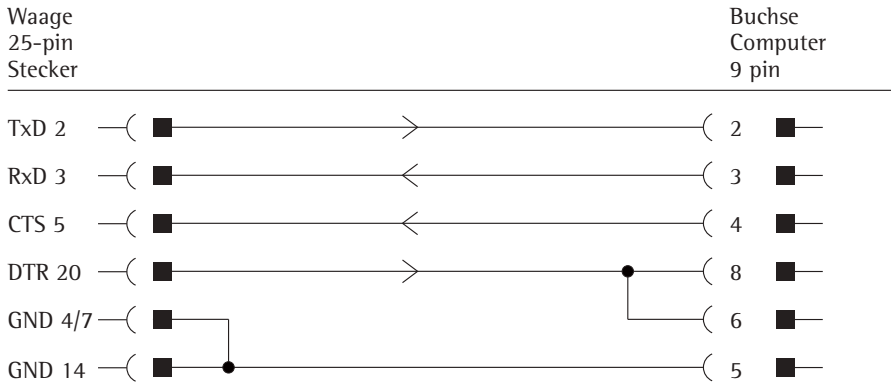

Cable type: AWG 24 specification

Troubleshooting Guide

Error codes are displayed for about 2 seconds. The program then returns automatically to the weighing mode.

Problem	Cause	Solution
<i>HIGH</i> or <i>ERR 55</i>	Weighing capacity exceeded	Unload the weighing pan
<i>LOW</i> or <i>ERR 54</i>	Contact between load plate and environment; load on weighing pan too light	Weighing pan must not be in contact with surrounding parts.
<i>APP.ERR.</i>	Cannot save data: Load on weighing pan too light or no sample on pan while application is active	Increase load.
<i>BIS.ERR.</i>	Data output not compatible with output format	Set the correct output format in the menu.
<i>PRT.ERR.</i>	Data interface for printout locked	Reset menu factory settings or contact your local Sartorius Service Center.
<i>ERR 02</i>	Calibration parameter not met, e.g.: – Unstable – Tare – Scale loaded	Correct the setup conditions. Do not carry out adjustment until after 0 display. Unload the scale.
<i>ERR 10</i>	„Tare“ function is locked for active application program „Net total“; Only 1 tare function can be used at a time	Clear the tare memory to unlock the „Tare“ function.
<i>ERR 11</i>	Tare memory not allowed	Carry out „Tare“ function.
<i>ERR 03</i>	Zero point error at the end of calibration	Check installation conditions; observe warm-up time. Repeat calibration
<i>ERR 06</i>	Int. calibration weight faulty or not available	Service
<i>ERR 08</i> <> Zero range	Error during zeroing (value outside 2%)	Change process.
<i>ERR 09</i> < 0 not allowed	Error during taring (tare value ≤0)	Change process.
<i>ERR 19</i> Preload is too high	The preload to be applied is too high	Change the preload value.
<i>ERR 30</i>	Balance scale is in BPI mode	Use service tool and built-in „Close“ function.
<i>ERR 50</i> or <i>53</i>	TC converter failure	Service
<i>ERR 241</i>	Checksum error	Service
<i>ERR 243</i>	Checksum error	Carry out menu reset.
<i>ERR 245</i> or <i>247</i>	Checksum error	Calibrate adjust balance scale.
<i>ERR 249</i>	Checksum error	Service
Weight readout changes constantly	Unstable ambient conditions (excessive vibration or draft) Foreign object is caught between weighing pan and housing	Change setup location. Adjust Setup configuration. Remove foreign object.
The weight readout is obviously wrong	Balance scale not calibrated adjusted Balance was not tared before weighing	Adjust Tare

If any other errors occur, contact your local Sartorius Service Center.

For contact information: go to: <http://www.sartorius.com>

Overview

Specifications

Standard specifications								Customer-specific modifications
Model		WZA25-NC	WZA224-N/-NC	WZA224-ND	WZA1203-N/-NC	WZA523-N/-NC	WZA8202-N/-NC	
Weighing capacity	g	20	220	220	1200	520	8200	
Readability	g	0.00001	0.0001	0.0001	0.001	0.001	0.01	
Maximum preload on pan support w/o limiting the weighing range, typical ²⁾	g	0	70	70	0	50	1300	
Required preload	g	5	-	-	-	-	-	
Tare range (subtractive)	g	of the maximum capacity						
Repeatability (standard deviation) ¹⁾	<±g	0.00002	0.0001	0.0001	0.001	0.001	0.01	
Linearity	<±g	0.00005	0.0002	0.0002	0.002	0.002	0.02	
Response time ³⁾	s	0.8 s/0.01 mg	0.6 s/0.1 mg	0.25 s/1 mg	0.6 s/1.0 mg	0.6 s/1.0 mg	0.6 s/1.0 mg	
Adaptation to ambient conditions		By selection of 1 of 4 optimized filter levels						
Operating temperature range °C		+10 ... +30 °C						
Allowable ambient operating temperature	°C	+5...+40 °C						
Sensitivity drift within +10... +30 °C	<±/K	1 • 10 ⁻⁶	1 • 10 ⁻⁶	1 • 10 ⁻⁶	2 • 10 ⁻⁶	2 • 10 ⁻⁶	2 • 10 ⁻⁶	
External calibration weight (of at least accuracy class...)	g	10 (E2)	50 (E2)	50 (E2)	500 (E2)	200 (F1)	2000 (E2)	
Material:								
- Weigh cell:		VA (14404, (AISI 316L) Pan stud: titanium	VA (load receptor: chemically nickel-plated aluminum)					
- Electronics module:		Transparently passivated aluminum						
Net weight, approximate	kg	2.0	2.0	2.0	2.0	2.0	2.8	
AC power source	V~	Sartorius AC adapter TNG6-2 100-240 VAC						
Supply voltage		+15%... 20% (IP protection IP20) -10% ... +10						
Frequency	Hz	50-60						
Alternatively:								
Supply voltage	VDc	min. 12 ... 26 max., optimal/15 V						
Ripple 50/60 Hz		0.5 Vpp (Voltage peak-to-peak)						
Power consumption		typically 3.4 W (weigh cell only)						
switch-on current		Average: 6 W (weigh cell only); with optional YAC01ED: display and control unit: 7.3 W (weigh cell + display and control unit)						
Built-in interface		RS-232C-S/V24-V28; 7-bit; even, mark, odd, space; transmission rates: 150...38400 baud, 1 or 2 stop bits; software/hardware handshake						

¹⁾ = depends on system design

²⁾ = for operation with greater preload setting, please send e-mail to request YAD018S configuration software; e-mail address: fast.factory@sartorius.com
Greater preloads are possible, but reduce the weighing capacity.

³⁾ = The weighing time is the time period in which the measured value oscillates within the stated range of the static end value.
Test weight approx. 25% of max.

Overview

Dimensions (Scale Drawings)

Electronics module:

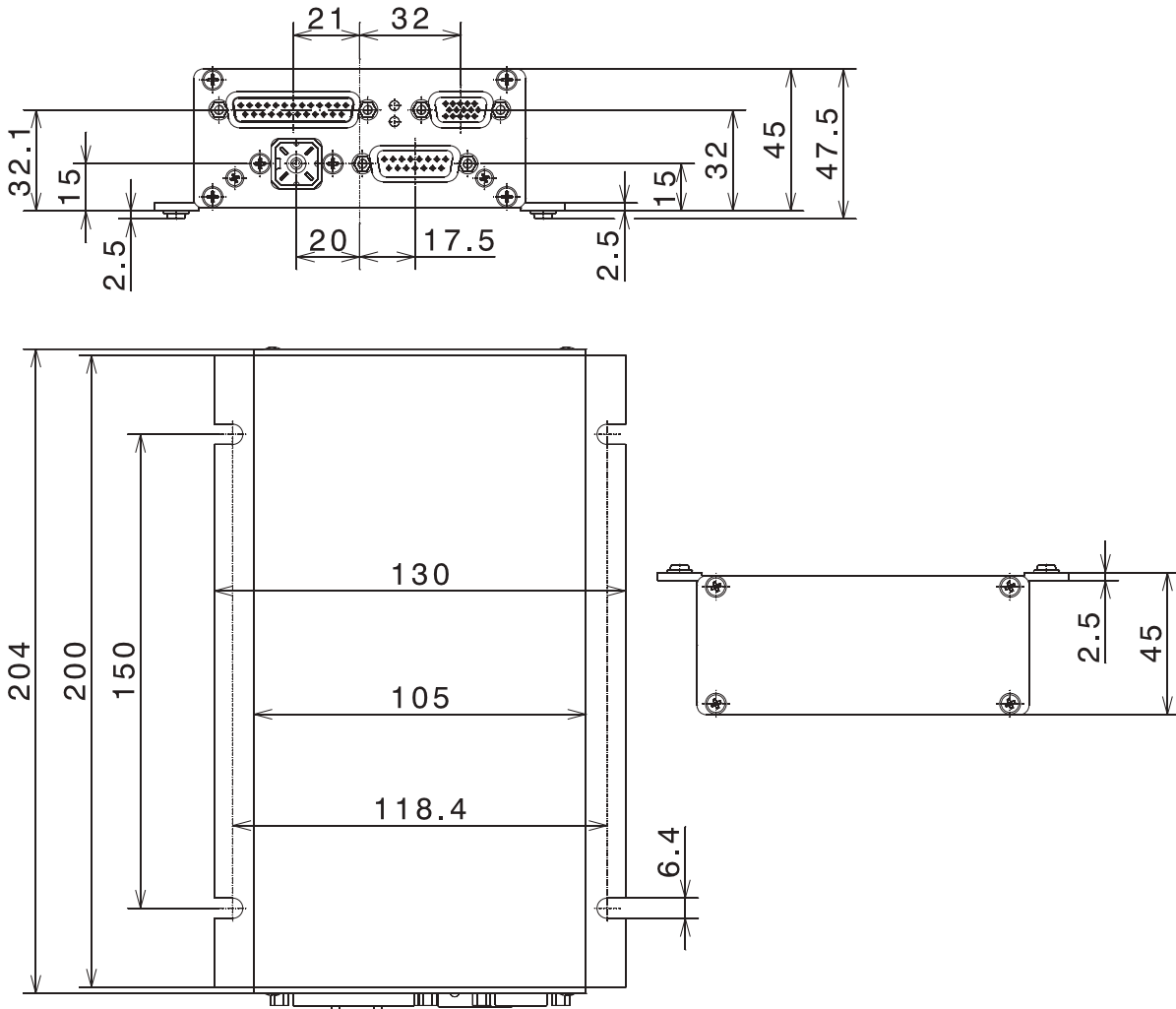

Optional YAC01ED Display and Control Unit:

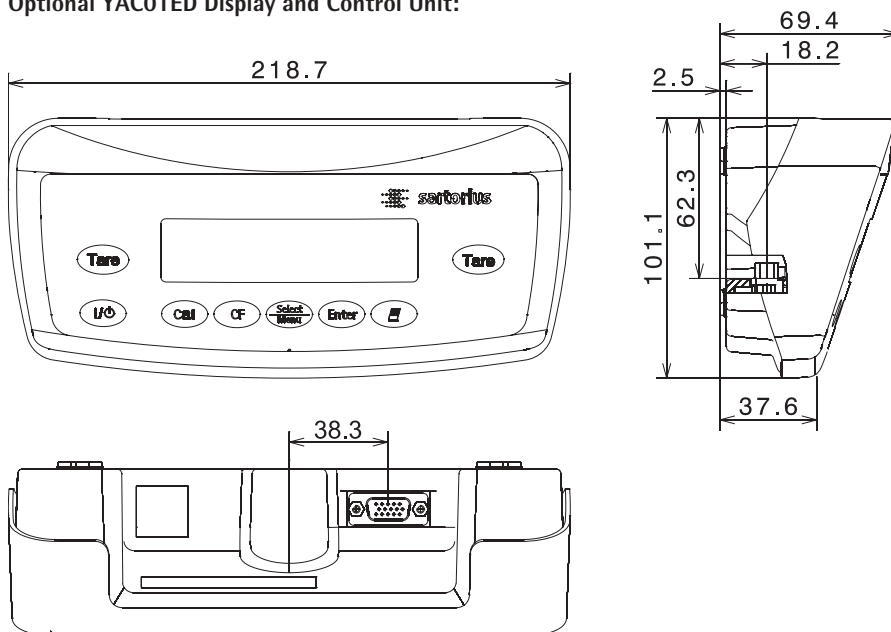

All dimensions are given in millimeters

Weigh cell models:

WZA224-N, WZA224-ND, WZA1203-N and WZA523-N

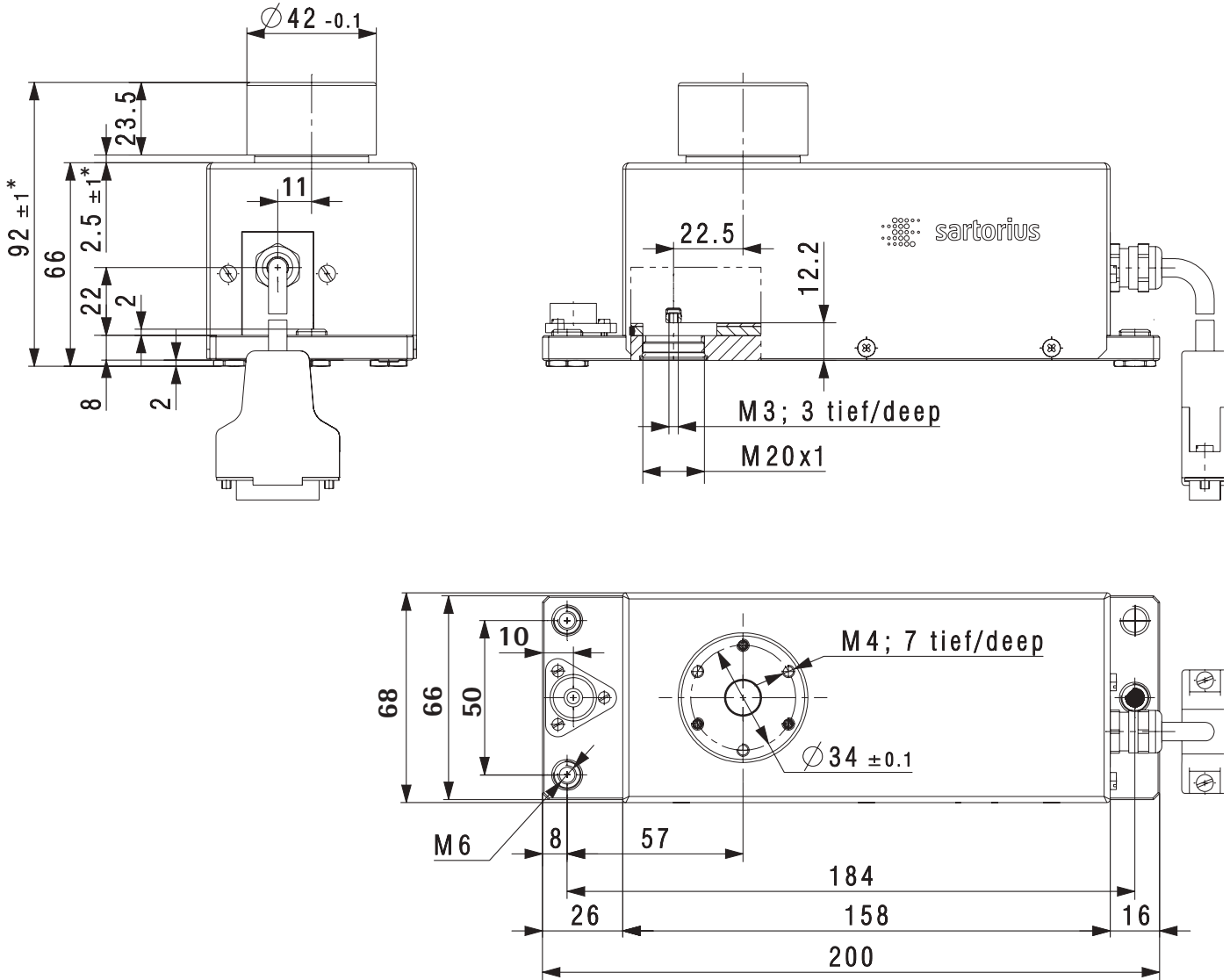

Kabellänge: 3 m
 15-pol. D-Sub-Stecker
 zur Sartorius-Elektronikbox
 Cable length: 3 m
 15-pin D-Sub male connector
 for Sartorius electronic PCB box

Werkstoffe / Materials:
 Grundplatte: V2A
 Base plate: AISI 304
 Haube: V2A
 Housing cover: AISI 304
 Lastflansch: V2A
 Load flange: AISI 304
 Libelle: Aluminium (blank)
 Level indicator: Aluminium (without finish)

Schutzklasse der Zelle: IP44
 Type of protection of weigh cell: IP44

* Einstellbereich

All dimensions are given in millimeters

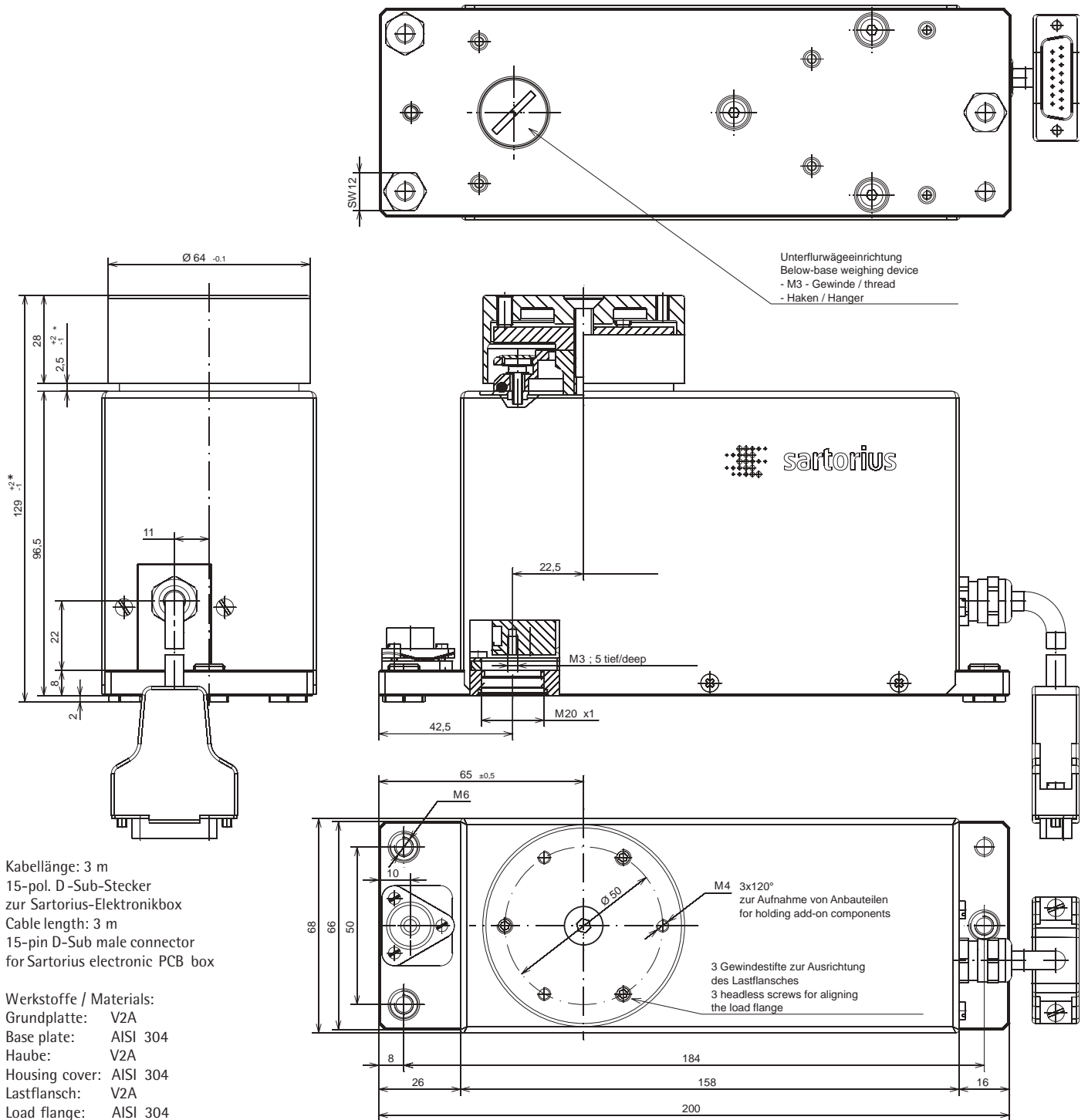

Kabellänge: 3 m
15-pol. D-Sub-Stecker
zur Sartorius-Elektronikbox
Cable length: 3 m
15-pin D-Sub male connector
for Sartorius electronic PCB box

Werkstoffe / Materials:
Grundplatte: V2A
Base plate: AISI 304
Haube: V2A
Housing cover: AISI 304
Lastflansch: V2A
Load flange: AISI 304
Libelle: Aluminium (blank)
Level indicator: Aluminium (without finish)

Schutzklasse der Zelle: IP44
Type of protection of weigh cell: IP44

* Einstellbereich

All dimensions are given in millimeters

**Weigh cell model:
WZA25-NC**

Kabellänge: 3 m
15-pol. D-Sub-Stecker
zur Sartorius-Elektronikbox
Cable length: 3 m
15-pin D-Sub male connector
for Sartorius electronic PCB box

Werkstoffe / Materials:
Grundplatte: V2A
Base plate: AISI 304
Haube: V2A
Housing cover: AISI 304
Lastflansch: V2A
Load flange: AISI 304
Libelle: Aluminium (blank)
Level indicator: Aluminium (without finish)

Schutzklasse der Zelle: IP44
Type of protection of weigh cell: IP44

* Einstellbereich

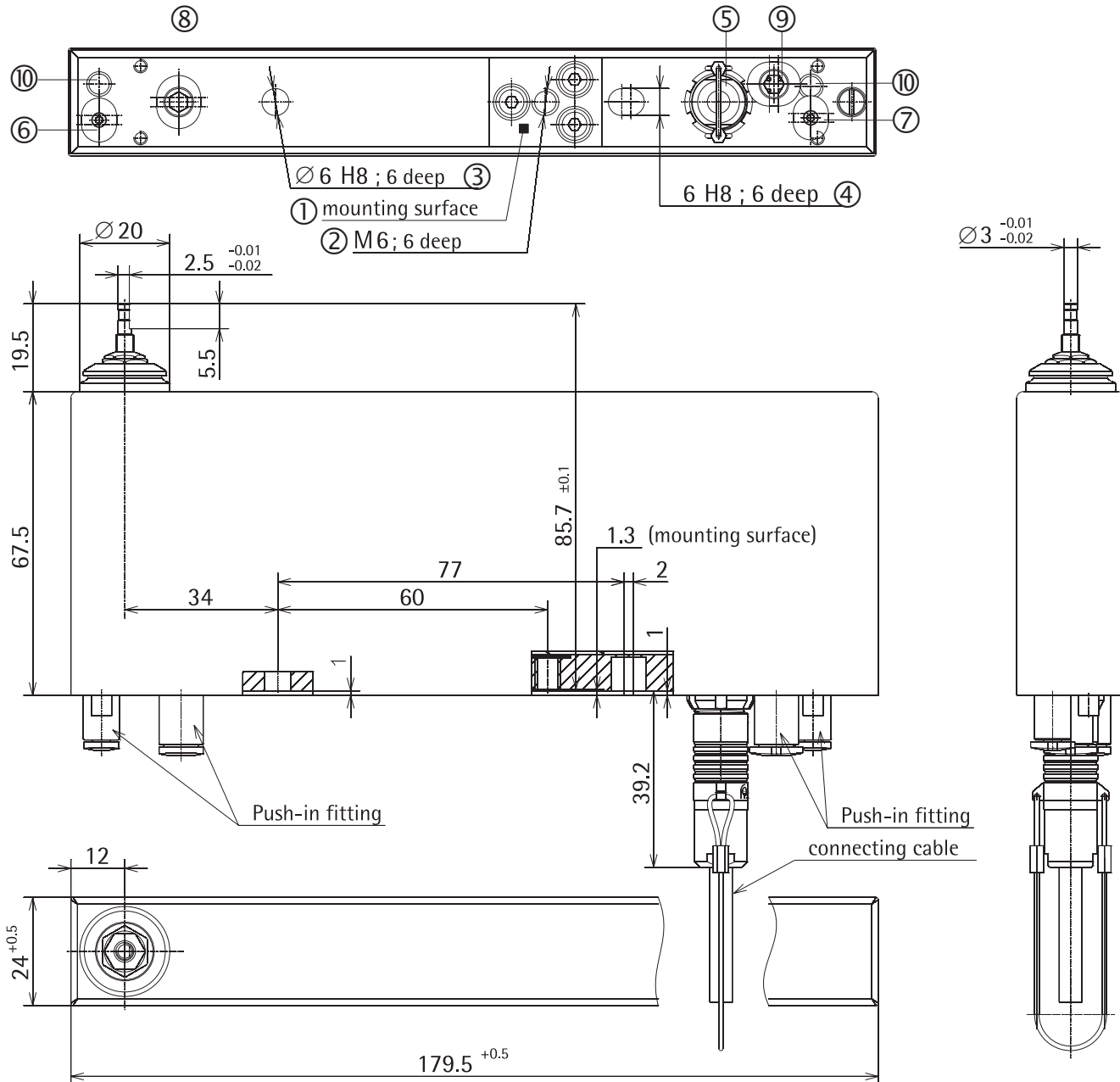

Pos.	Designation
1	Mounting surface
2	Threaded hole for mounting
3, 4	Positioning holes
5	Electrical connection
6	Pressure inlet Cal.-weight circuit mechanism 6 bar, $\varnothing 3$ mm

Pos.	Designation
7	Pressure inlet closing mechanism 6 bar, $\varnothing 3$ mm
8	Air inlet for rinsing cycle ≤ 50 mbar, $\varnothing 6$ mm
9	Air outlet for rinsing cycle ≤ 50 mbar, $\varnothing 6$ mm
10	Pressure outlet for 6 and 7



Users should never change any other screws!

All dimensions are given in millimeters

Dimensions (Scale Drawings)

Weigh cell models:
WZA224-NC, WZA523-NC, WZA1203-NC

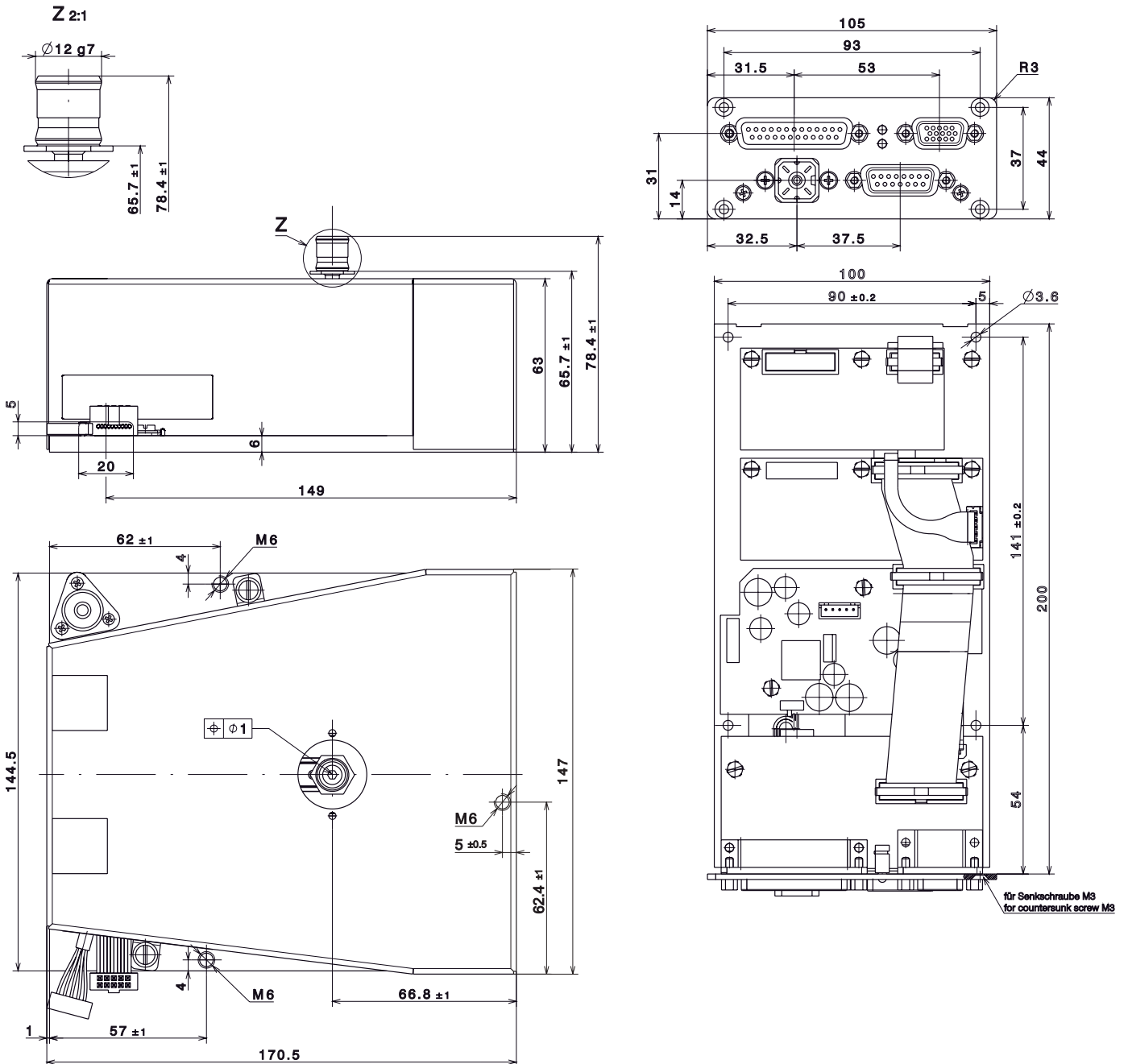

Kabellänge: 3 m
15-pol. D-Sub-Stecker
zur Sartorius-Elektronikbox
Cable length: 3 m
15-pin D-Sub male connector
for Sartorius electronic PCB box

Werkstoffe / Materials:
Grundplatte: V2A
Base plate: AISI 304
Haube: V2A
Housing cover: AISI 304
Lastflansch: V2A
Load flange: AISI 304
Libelle: Aluminium (blank)
Level indicator: Aluminium (without finish)

Schutzklasse der Zelle: IP44
Type of protection of weigh cell: IP44

* Einstellbereich

All dimensions are given in millimeters

Dimensions (Scale Drawings)

Weigh cell WZA8202-NC

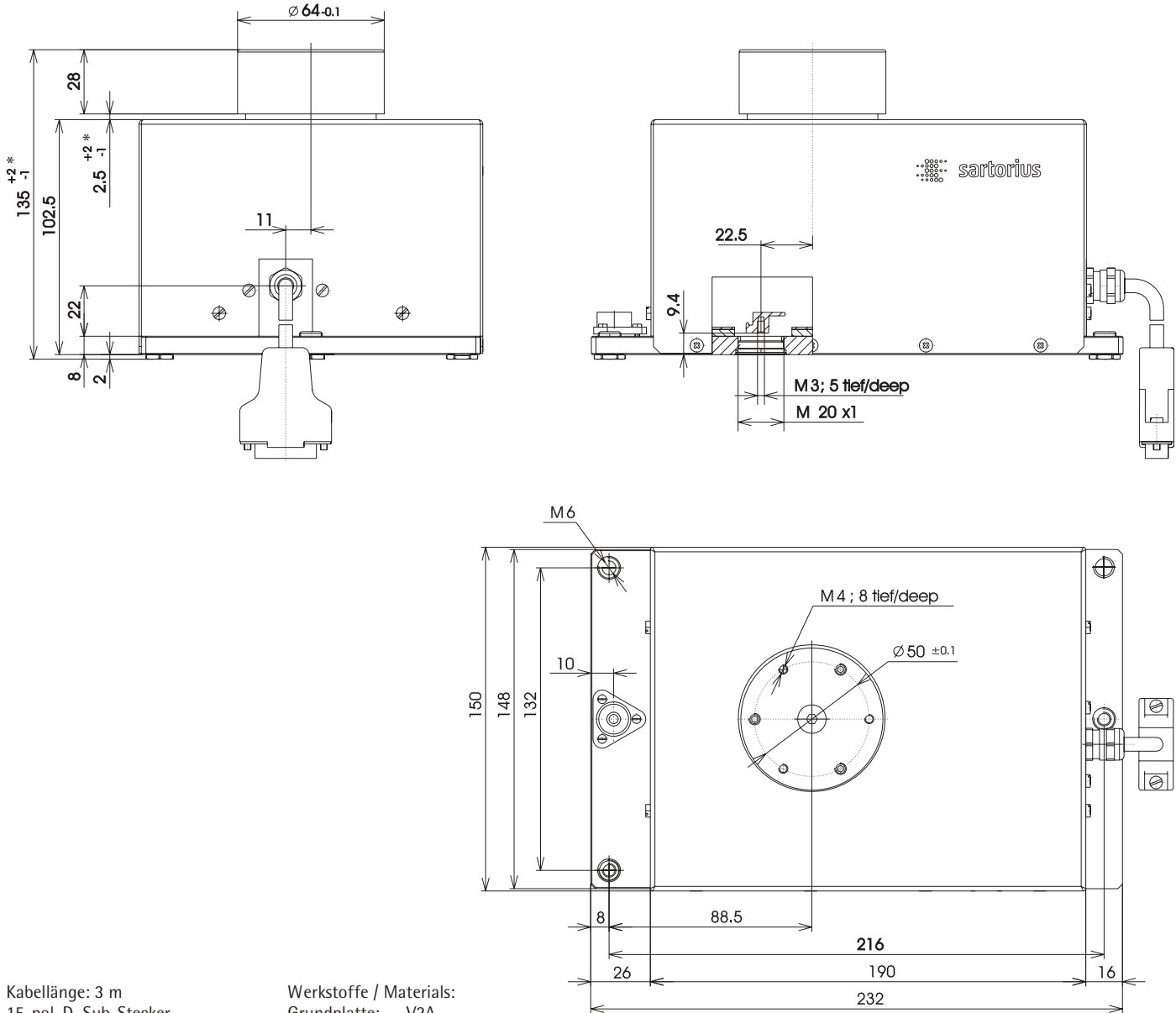

Kabellänge: 3 m
 15-pol. D-Sub-Stecker
 zur Sartorius-Elektronikbox
 Cable length: 3 m
 15-pin D-Sub male connector
 for Sartorius electronic PCB box

Werkstoffe / Materials:
 Grundplatte: V2A
 Base plate: AISI 304
 Haube: V2A
 Housing cover: AISI 304
 Lastflansch: V2A
 Load flange: AISI 304
 Libelle: Aluminium (blank)
 Level indicator: Aluminium (without finish)

Schutzklasse der Zelle: IP44
 Type of protection of weigh cell: IP44

* Einstellbereich

All dimensions are given in millimeters

Accessories

Product	Order No.
Display and control unit with cable (0.9 m) for connection to enclosed electronics module	YAC01ED
Second display for connection to data interface	YRD03Z
Configuration software for settings, calibration/adjustment and setting the preload	Sartorius CAS-Suite
SartoConnect data transfer software (for loading weight values in a PC running Windows® 95/98/NT and direct processing with application programs such as Excel, Access, etc.) incl. adapter cable (1.5 m) from weigh cell to PC (12-pin to 9-pin)	YSC011
Data cables RS-232	
- for PC connection, 25-pin	7357312
- for PC connection, 9-pin	7357314
AC adapter STNG-2	
IP40 protection in accordance with VDE* 0470/529	
- Europe	6971886 or 6971961 + 6900900
- US	6971961 + 6900901
- UK	6971961 + 6971945
- South Korea	6971961 + 6900900
Additional options and accessories available on request	

* VDE = Verband der Elektrotechnik, Elektronik, Informationstechnik
(Association for Electrical, Electronic & Information Technologies)



CE **EG-Konformitätserklärung**
EC Declaration of Conformity

Sartorius AG
Weender Landstr. 94 - 108
37075 Göttingen, Germany

erklärt, dass das Betriebsmittel
declares that the equipment

Gerät: Präzisionswaagezelle mit Anzeige- und Bedieneinheit
Apparatus: High Precision Load Cell with Display and Operating Unit

Reihe / *type*: WZA...-N, YAC01ED

Typbezeichnung: Siehe Anhang 1
Type: See Annex 1

mit den grundlegenden Anforderungen der folgenden Europäischen Richtlinien übereinstimmt;
complies with the basic requirements of the following European Directives:

Richtlinie 2004/108/EG <i>Directive 2004/108/EC</i>	Elektromagnetische Verträglichkeit <i>Electromagnetic compatibility</i>
Richtlinie 2006/95/EG <i>Directive 2006/95/EC</i>	Elektrische Betriebsmittel zur Verwendung innerhalb bestimmter Spannungsgrenzen <i>Electrical equipment designed for use within certain voltage limits</i>

Das Gerät erfüllt die anwendbaren Anforderungen der in Anhang 2 aufgeführten harmonisierten Europäischen Normen.
The apparatus meets the applicable requirements of the harmonized European Standards listed in Annex 2.

Sartorius Mechatronics
Göttingen, 2009-08-10

C. Oldendorf
Präsident, Fertigung Technologie & Innovation
Sparte Mechatronik
Vize Präsident, R&D
Technical Operations & Research
Mechatronics Division

Dr. D. Klausjeter
Leitung International Certification Management
Sparte Mechatronik
Head of International Certification Management
Mechatronics Division



Konformitätserklärung *Declaration of Conformity*

Sartorius Weighing Technology GmbH
Weender Landstr. 94 - 108
37075 Goettingen, Germany

erklärt, dass das Betriebsmittel
declares that the equipment

Geräteart: Präzisionswaage mit Anzeige- und Bedieninheit
Device type: High Precision Load Cell with Display and Operating Unit

Baureihe / type series: WZA...-N. + YAC01ED

Übereinstimmt mit den Regelungen der Europäischen Richtlinie (in der heute gültigen Fassung):
complies with the regulations of the European Directive (in the today valid version)

Richtlinie 2002/95/EG: Zur Beschränkung der Verwendung bestimmter gefährlicher Stoffe
in Elektro- und Elektronikgeräten

*Directive 2002/95/EC: on the restriction of the use of certain hazardous substances in electrical
and electronic equipment*

sobfern das Betriebsmittel gekennzeichnet ist mit:
provided that the equipment is marked with:



Sartorius Weighing Technology GmbH
Goettingen, 2011-08-17

Dr. Reinhard Baumfalk
Vize President R&D

Dr. Dieter Klausgrube
Eritung International Certification Management
Head of International Certification Management

Diese Erklärung bescheinigt die Übereinstimmung mit der genannten EG-Richtlinie, ist jedoch keine Zusicherung
von Eigenschaften. Bei einer mit uns nicht abgestimmten Änderung des Produktes verliert diese Erklärung ihre
Gültigkeit.

*This declaration certifies conformity with the above mentioned EC Directive, but does not guarantee product
attributes. Unauthorised product modifications make this declaration invalid.*



Certificate of Compliance

Certificate: 1928438

Master Contract: 167555

Project: 1928438

Date Issued: 2006/01/09

Issued to: Sartorius AG
Weender Landstrasse 94-108
Postfach 3243
Goettingen, 37075
Germany
Attention: Dr. Dieter Klausgrete

The products listed below are eligible to bear the CSA Mark shown with adjacent indicators 'C' and 'US'



Issued by: J. Beauchamp

Authorized by: Gianluca Arcari, P.Eng., MBA,
Product Group Manager

PRODUCTS

CLASS 8721 85 - ELECTRICAL EQUIPMENT FOR LABORATORY USE - Certified to US Standards

CLASS 8721 05 - LABORATORY EQUIPMENT - Electrical

Laboratory Scale

Part A: Model WZ or GPC series

The 'C' and 'US' indicators adjacent to the CSA Mark signify that the product has been evaluated to the applicable CSA and ANSI/UL Standards for use in Canada and the U.S., respectively. This 'US' indicator includes products eligible to bear the NRTL indicator. NRTL, i.e. National Recognized Testing Laboratory, is a designation granted by the U.S. Occupational Safety and Health Administration (OSHA) to laboratories which have been recognized to perform certification to U.S. Standards.



Certificate: 1928438

Master Contract: 167555

Project: 1928438

Date Issued: 2008/01/09

Part B: Model WZG series.

Part C: Model WZV series.

Note 1: Models WZ, GPC and WZG are Equipment Class 1, Pollution Degree 2, and Installation Category II.

Note 2: Model WZV is evaluated as a component where the suitability of the enclosure and power supply is to be evaluated.

CONDITIONS OF ACCEPTABILITY

The equipment is supplied with an approved power supply cord set that is acceptable to the authorities in the country where the equipment is to be used.

APPLICABLE REQUIREMENTS

CAN/CSA-C22.2 No. 61010-1-04 - Safety Requirements for Electrical Equipment for Measurement, Control, and Laboratory Use, Part 1: General Requirements

UL Std. No. 61010-1 (2nd Edition) - Safety Requirements for Electrical Equipment for Measurement, Control, and Laboratory Use - Part 1: General Requirements

Formular: Rücklieferung
Form: Return delivery



sartorius

Page 1 of 1

Bitte dieses Formular dem Gerät beilegen
Please attach this form to the instrument
being returned

Rücklieferungsnummer / Meldungsnummer Goods return number / Registration number
--

Zu beachten!
Um eine Gefährdung unserer Mitarbeiter
durch Kontaminationen ausschließen zu können,
ist eine Bearbeitung nur mit ausgefüllter
Dekontaminationserklärung möglich.

Important Note!
To protect our employees from health hazards
due to contamination, we will only accept return
products if we have a completely filled
Declaration of about Decontamination.

An To:		Von From:	
Sartorius Weighing Technology GmbH			
Servicezentrum Mechatronik / Geb. 15			
Weender Landstraße 94-108			
37070 Göttingen			
Germany			
Typ Model	Serien-Nr. Serial no.	Kunden-Nr. Customer no.	
Zubehör Accessories	Bestell-Nr. / Rechnungs-Nr. Order no. / Invoice no		

Informationen zur Rücksendung Informations on return delivery	
<input type="checkbox"/> Produkt defekt Product defective: <input type="checkbox"/> Lieferung unvollständig Delivery incomplete: <input type="checkbox"/> Falschlieferrung Wrong delivery: <input type="checkbox"/> Konsignationsgerät Goods on consignment: <input type="checkbox"/> Anderer Grund Other reason:	
<input type="checkbox"/> Nach Reparatur ins Fertiglager Return to stock after repair <input type="checkbox"/> Nach Reparatur zurück an Absender Return to sender after repair <input type="checkbox"/> Kostenvoranschlag an Quotation to: <input type="checkbox"/> Weiterleiten an Forward to: <input type="checkbox"/> Information an Information to: <input type="checkbox"/> Sonstiges / Bemerkungen Other / Remarks:	<input type="checkbox"/> Nach Reparatur ins 2.Wahl-Lager Return to second hand stock after repair <input type="checkbox"/> Entsorgen Scrap

 Kontaktperson | Contact person Tel.-Nr. | Phone no. Fax-Nr. | Fax no. Kostenstelle | Cost Center

 Datum | Unterschrift (Kontaktperson)
 Date | Signature (Contact person)

 Genehmigt | Datum | Unterschrift
 Approved | Date | Signature

Declaration about decontamination



Declaration about decontamination and cleaning of equipment and components

To protect our personnel, we require all equipment or components be free of biological, chemical, or radio active contaminants. We will only accept such equipment or components when:

- the equipment or components have been adequately CLEANED and DECONTAMINATED.
- this declaring document has been completed, signed and returned by an authorized person.

Please help us in assuring a safe, hazard-free work environment.

Description of the Equipment or Component(s)

Description / Cat. No.:	
Serial no.:	
No. of invoice/delivery note	
Date of delivery:	

Contamination / Cleaning

Attention: Please specify exactly the biological, chemical, or radioisotopic contaminant.	Attention: Please describe the cleaning and decontamination procedure/method.
The equipment was contaminated with:	and it has been cleaned and decontaminated by

Legally binding declaration

I (we) certify that all information given in this form is correct and complete.
The equipment and components have been adequately decontaminated and cleaned according to the legal requirements. No chemical or biological or radio active risks remain that can endanger exposed persons' safety or health.

Company / Institute:			
Address / Country:			
Tel.:		Fax (with area code):	
Name of the authorized person:			
Position:			
Signature / Date:			

Please pack the equipment properly and send it to your local service representative or to Sartorius Weighing Technology GmbH, Germany.

Sartorius Weighing Technology GmbH Servicezentrum Mechatronik Weender Landstraße 94-108 37070 Göttingen Deutschland

Sartorius Weighing Technology GmbH
Weender Landstrasse 94–108
37075 Goettingen, Germany

Phone +49.551.308.0
Fax +49.551.308.3289
www.sartorius.com

Copyright by Sartorius,
Goettingen, Germany.
All rights reserved. No part
of this publication may
be reprinted or translated in
any form or by any means
without the prior written
permission of Sartorius.
The status of the information,
specifications and illustrations
in this manual is indicated
by the date given below.
Sartorius reserves the
right to make changes to
the technology, features,
specifications and design of
the equipment without notice.

Status:
March 2014,
Sartorius Weighing Technology GmbH,
Goettingen, Germany