

Installation Instructions

Sartorius Weigh Cells

Models WZA...-L, WZA224-LC

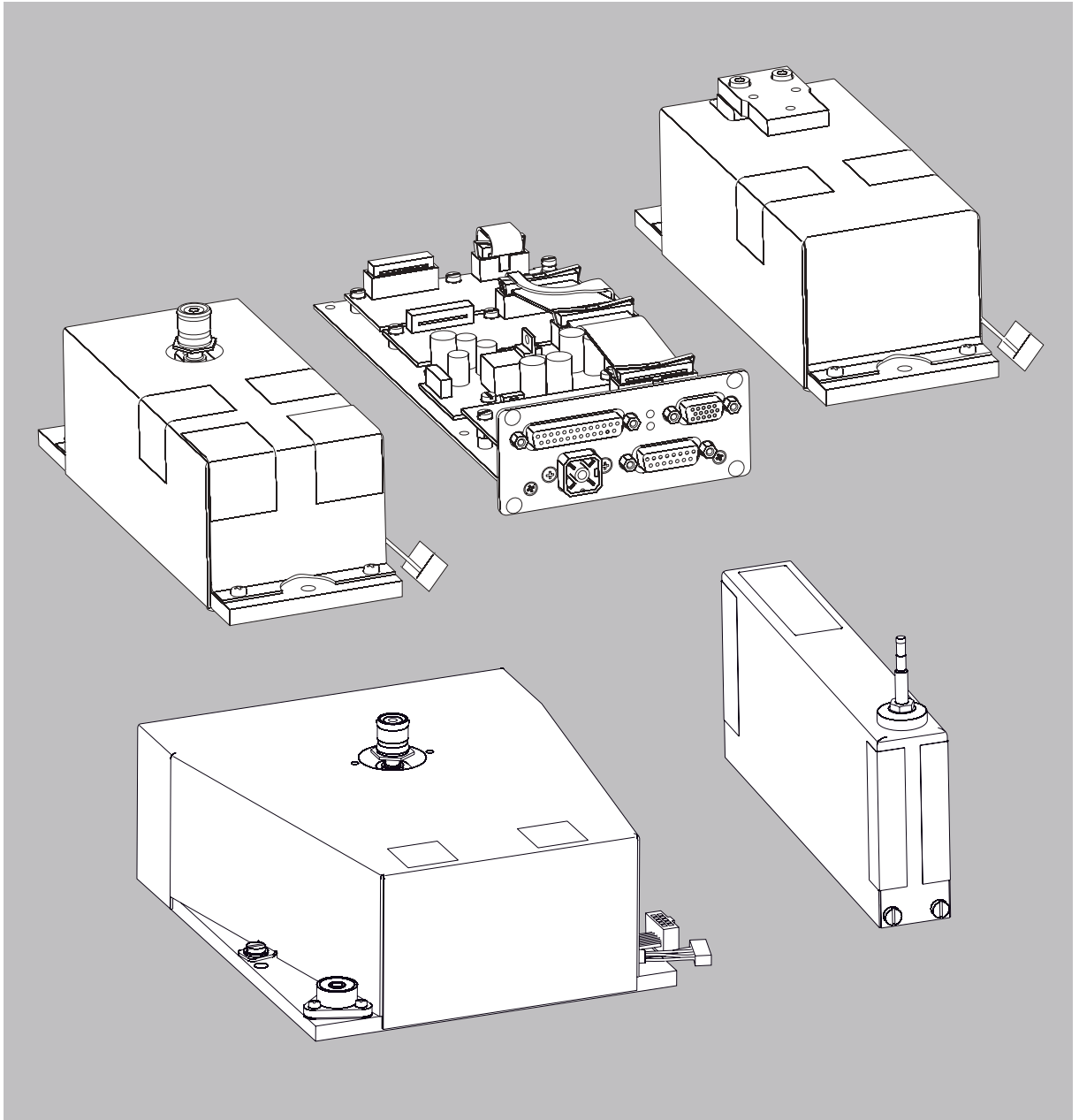

Contents	2
Warning and Safety Instructions	2
General View of the Equipment	3
Installation	5
Storage and Shipping Conditions	5
Incoming Inspection	5
Equipment Supplied	5
Installation Instructions	5
Connecting the Weigh Cell to the Electronics Unit	5
Connecting the Device to AC Power	6
Securing the Weigh Cell	7
Leveling the Load Receptor	7
Securing the Transducer	7
Operation	9
Notes on Analytical Weighing	9
Below-Cell Weighing	10
Configuration	13
Parameter Settings (Overview)	16
Data Interface Port: RS-232	24
Pin Assignment Chart	26
Cabling Diagram	27
Error Codes	28
Overview	30
Specifications	30
Dimensions (Scale Drawings)	31
Accessories (Options)	36
Form: Returns	38
Decontamination Declaration	39

Intended Use

- Weigh cells have been developed for
 - Use in measuring devices and production machinery
 - High-precision weighing within limited space
 - Precise weight determination on active production lines
- ⚠ The weigh cells are not devices; they are modules to be added on. Only create an EC Declaration of Conformity once the device has been finalized. Direct sale to end customers is not permitted due to the lack of a CE marking.

System Description

- The products are comprised of two components:
 - A compact weigh cell that must be secured at three points
 - Electronics unit
- These compact weigh cells can be used to determine weights within restricted space.

Safety

- The user of the weigh cell should take into account at least the following points with regards to the complete product with the installed weigh cell:
 - Compliance with directives and standards for electrical equipment
 - Electromagnetic compatibility of the complete device
 - Compliance with mandatory safety regulations.
 - Read these installation instructions thoroughly before using your weigh cell. That way you will prevent damage to the equipment.
 - These installation instructions only describe the technological specifications of the weigh cell and the conditions that must be observed during installation.
 - ⚠ Always make sure that the equipment is disconnected from power before performing any work on it.
- ## Installation
- ⚠ Do not use this equipment in hazardous areas, zones exposed to explosive gases or dusts, nor areas exposed to potentially explosive materials.
 - ⚠ Use of the weigh cell in areas where medical equipment is operated is not permitted.
 - ⚠ Do not mix up weigh cell and electronics unit:
 - Only connect devices that are made to be operated together. Make sure that the serial numbers match.
 - ⚠ Any improper handling, modifications or installation work will result in forfeiture of all claims under the warranty.
 - ⚠ The requirements pertaining to applicable installation regulations must be followed when using electrical equipment in systems and environmental conditions with increased safety requirements.
 - ⚠ Installation of electronics unit:
 - The electronics must be installed as set out in the guideline for EMC compatibility.
- Warning: RS-232 cables purchased from other manufacturers: RS-232 cables purchased from other manufacturers often have incorrect pin assignments for use with Sartorius equipment. Be sure to check the pin assignments against the chart in this manual before connecting the cable, and disconnect any lines identified differently from those specified by Sartorius.
 - Note on Installation:
 - The operator shall be responsible for any modifications to the equipment and for any connections of cables or equipment not supplied by Sartorius and must check and, if necessary, correct these modifications and connections.
 - If there is visible damage to the components: Disconnect from the supply voltage and replace the weigh cell and electronics unit:
 - Do not unnecessarily expose the device to aggressive chemical vapors or to extreme temperatures, moisture, shocks, or vibration.
 - If you have any problems with your device:
 - contact your local Sartorius office, dealer or service center.
- ## Hotline
- Please direct technical questions on design, specifications and installation to your operating partner or directly to Sartorius, at the hotline:
 - Phone: +49.551/308-4440
 - Phone: +49.551/308-4449

Overview of Equipment

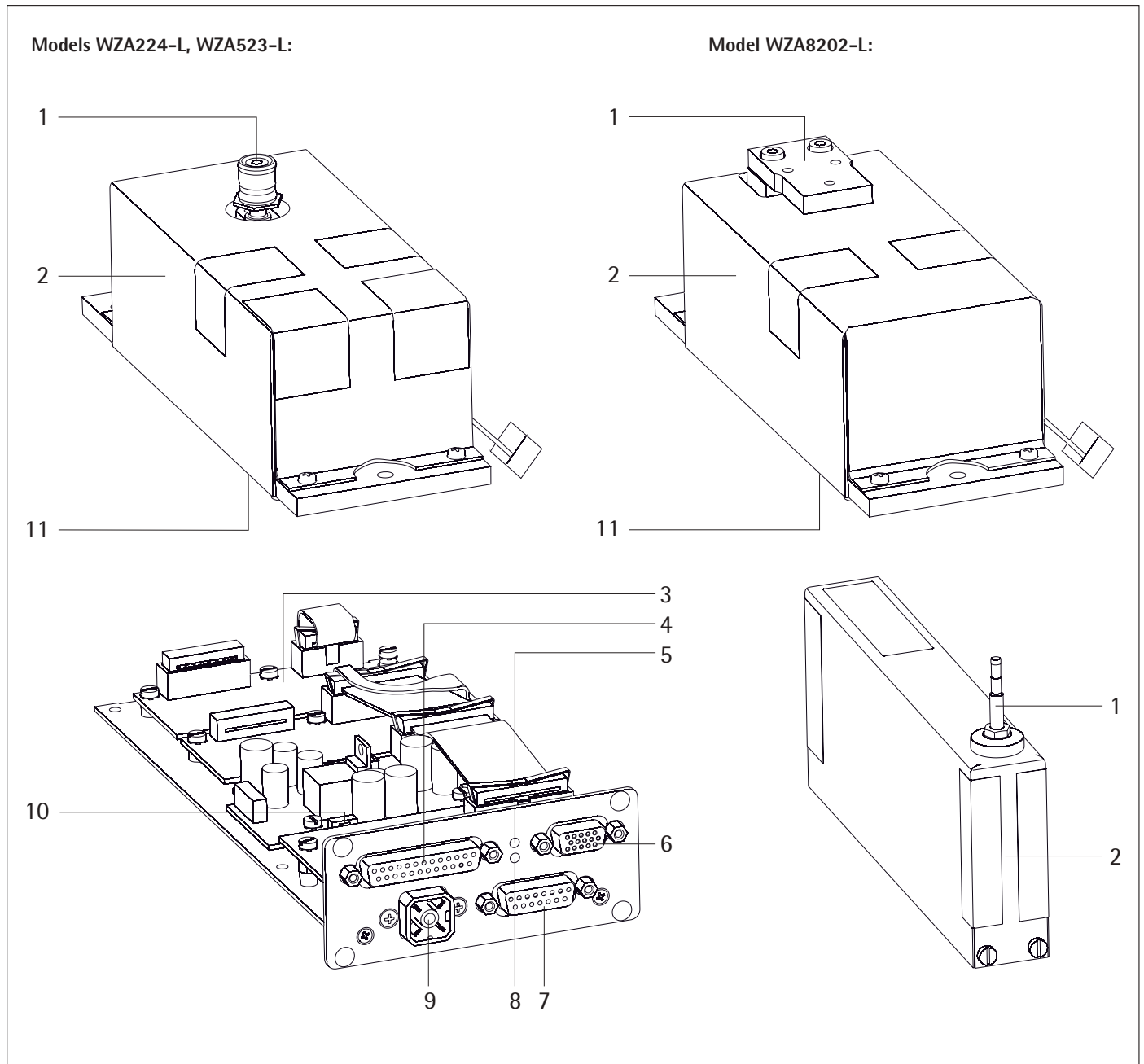

Pos.	Description
1	Load receptor
2	Weigh cell
3	Electronics unit
4	Interface port
5	LED: RxD/DC jack (yellow)

Pos.	Description
6	Female connector for optional display unit
7	Female connector for weigh cell
8	LED: TxD (red)
9	DC jack
10	Menu access switch
11	Hook for below-cell weighing

 Users should never alter any of the other screws!

Overview of Equipment

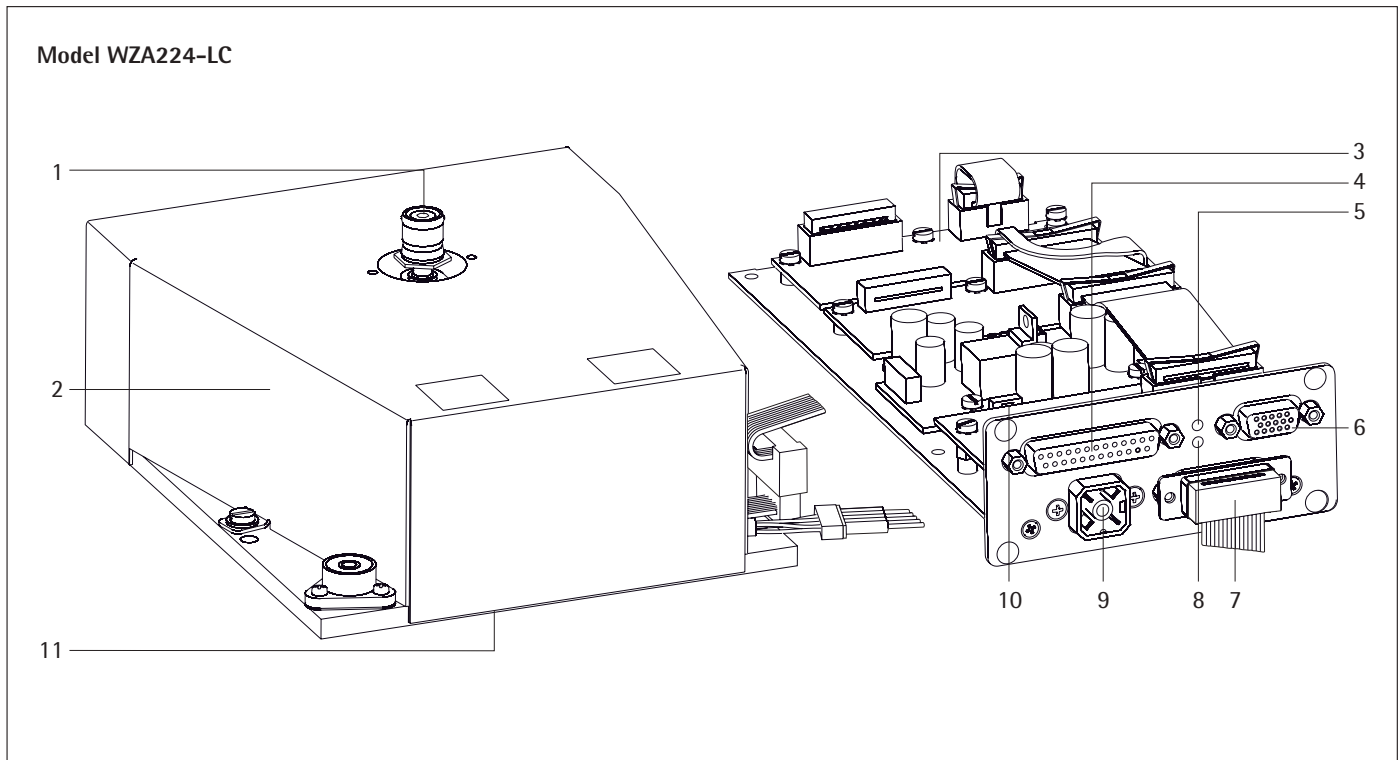

Pos.	Description
1	Load receptor
2	Weigh cell
3	Electronics unit
4	Interface port
5	LED: RxD/DC jack (yellow)
6	Female connector for optional display unit
7	Female connector for weigh cell
8	LED: TxD (red)
9	DC jack
10	Menu access switch
11	Hook for below-cell weighing

 Users should never alter any of the other screws!

Installation

Storage and Shipping Conditions

- Once the equipment has been removed from the packaging, it may lose accuracy if subjected to strong vibration.
- Do not expose the equipment to unnecessarily extreme temperatures, moisture, shocks, blows or vibration.
- It is a good idea to save the box and all parts of the packaging. Only the original packaging provides the best protection for shipment.
- Before packing your equipment for shipping, unplug all connected cables to prevent unnecessary damage.
- Do not expose the equipment to gravitational acceleration in excess of 300 m/s² (unless additional equipment is installed on the load receptor).

Incoming Inspection

The customer shall inspect the product and packaging immediately upon delivery for proper functioning, completeness and absence of defects. This is to be performed in an incoming inspection within 10 days of delivery of the product or service. The incoming inspection must take place before the equipment is installed. Any obvious defects, errors, or incorrect delivery must be reported in writing. Defects detected at a later date must be reported in writing immediately upon detection.

Be sure to perform the following as part of the incoming inspection:

- We recommend performing a repeatability test using an auxiliary draft shield to make sure there was no damage during transport. Sartorius PC configuration software can be used as a tool for this.

Equipment Supplied

- Weigh cell
 - Electronics unit
 - Installation instructions (this manual)
 - AC adapter
 - Special accessories as listed on the bill of delivery or in accordance with any customer-specific agreement
- An extension cord (weigh cell – electronics) is not included in the equipment supplied. If required, order separately or follow the notes on creating an extension cord connection.

Installation Instructions

The weigh cell is delivered in antistatic packaging along with its associated analog electronics.

The other electronic components are packaged separately on a base plate in an antistatic bag.

Before operating, always make sure that the serial numbers of the weigh cell and the electronics match.

The corresponding cable must be securely inserted into the electronics before initial startup.

The device is designed to deliver reliable weighing results when installed properly. If you have any questions or difficulties setting up your weighing system, please contact the specialists at Sartorius. When designing and setting up the weigh cell and the electronics unit, please observe the following so that you will be able to work with added speed and accuracy:

- Avoid exposing the equipment to the effects of extremely high temperatures; for example, caused by other electronic components, heaters or direct sunlight.
- Protect the equipment from direct drafts that come from open windows or doors.
- Avoid exposing the equipment to excessive vibrations during weighing; for example, caused by motors or valves.

- Protect the equipment from aggressive chemical vapors.
- Avoid extreme moisture.
- Switch the system to Standby mode when not in use.
- Avoid the effects of magnetism.

△ Always calibrate/adjust the weigh cells after transport.

- Equipment installed on the load receptor can interfere with weigh cell functions. The user accepts all liability for production release and the specifications of the entire equipment. The specifications attained by your system may differ from those listed in the "Specifications" chapter.

Conditioning the equipment:
Moisture in the air can condense on the surface of a cold weighing instrument or other device whenever it is moved to a substantially warmer place. If you transfer the equipment to a warmer area, make sure to condition it for about two hours at room temperature, leaving it unplugged from AC power.

WZA...L:

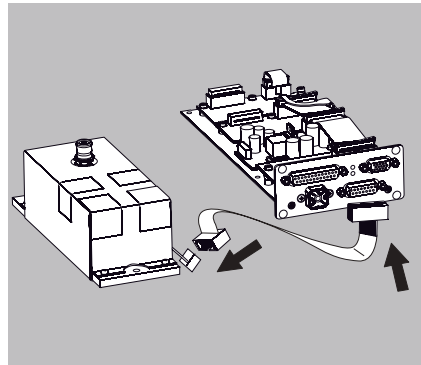

WZA224-LC:

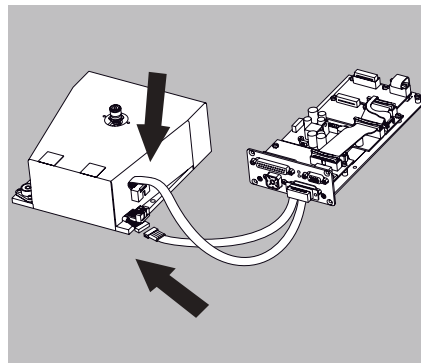

Connecting the Weigh Cell to the Electronics Module

- Plug the male connector of the connecting cable into the socket of the electronics unit and the weigh cell

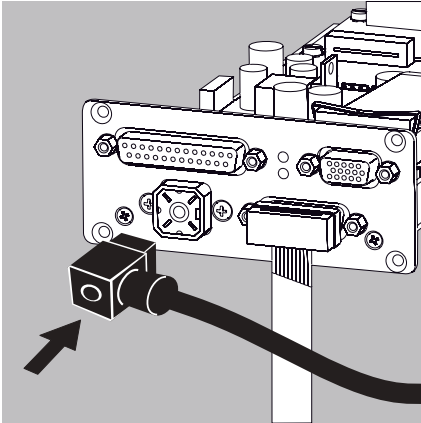

- **Connecting the Device to AC Power**
- Check the voltage rating and the plug design.
If they do not match your local rating or standard: Contact your supplier
- Use only
 - Original Sartorius AC adapters and power supplies
 - AC adapters approved by specialist technicians
- Insert the right-angle plug from the AC adapter into the jack on the electronics module and tighten the fastening screw
- Connect the equipment to power:
 - Plug the AC adapter into the wall outlet (mains)
- After connecting the power supply: The "RxD/Power" LED lights up yellow
- Power is supplied through the DC jack (Hirschmann plug).
If the stated supply voltage or the plug design of the power cord does not comply with your country's standard, please inform the nearest Sartorius representative or your dealer.
- Using an AC adapter other than that supplied with the equipment:
The device can be operated with a supply voltage of 12V to max. 26V.
- ⚠ The power connection must be made in accordance with the regulations applicable in your country.

Safety requirements for operation of the evaluation electronics connected to a safety extra-low voltage (SELV) source

Safety requirements:

The external power supply must meet the requirements of EN 61010-1, Section 6: Protection Against Shock Current. Please also refer to the specifications for classification of electrically operated equipment in EN 61010-1.

Safety precautions:

The power supply must be rated to safety extra low voltage (SELV) or grounded (earthed) safety extra low voltage (SELV-E).
An adaptor rated to Class 2 can be plugged into any wall outlet with no additional safety precautions required. A ground or earth terminal is connected to the housing.
The electronics module must be grounded for operation. The data interface is also electrically connected (grounded) to the weigh cell housing.

EMC requirements:

The connector is designed for DC connections between equipment/systems that are not connected to a DC power supply.
The cable length must not exceed 3 m.

To use an external power supply, the power source must meet the requirements of EN 61326. The following standards apply:

Fast transients	IEC61000-4-4
Surge voltages	IEC 61000-4-5
Conductive HF signals	IEC61000-4-6

Socket, electronics unit	Type: G 4 A 5 M
Suitable matching piece	Type: G 4 W 1 F, Hirschmann order no. 932157-100

Hirschmann Electronics GmbH & Co.
Stuttgarter Strasse 45-51
72654 Neckartenzlingen
Germany

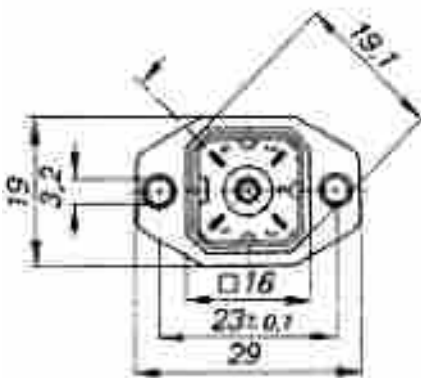

Sizes in mm

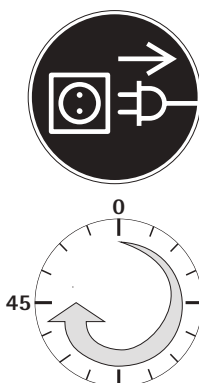

- **Connecting Electronic Peripheral Devices**
- Make absolutely sure to unplug the weigh cell from AC power before you connect or disconnect a peripheral device (e.g., PC) to or from the interface port.

Warm-up Time

The amount of warm-up time required depends in part on the system used.
The guideline for these weigh cells is approx. 45 minutes. However, this guideline must be verified by the user for the respective system/application.

WZA...-L:

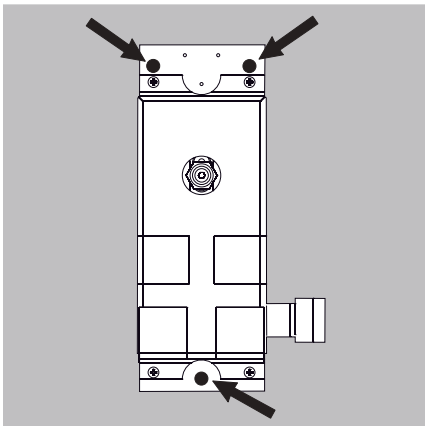

Securing the Weigh Cell

- Install the weigh cell level for optimal operation.
- The weigh cell should be secured to the system fastening frame via the 3 drill holes.

WZA224-LC:

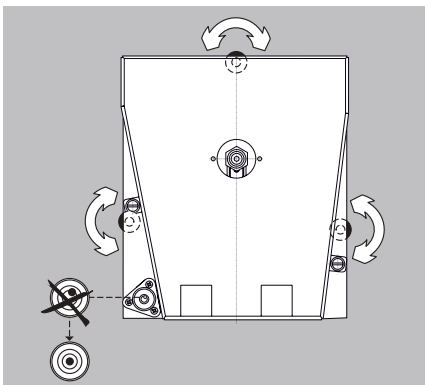

WZA224-LC:

Leveling the Weigh Cell in a Portable Weighing System

Purpose:

- To compensate for uneven areas at the place of installation.
- To ensure that the weigh cell is placed in a perfectly horizontal position for consistently reproducible weighing results.
- Always level the weigh cell again any time after it has been moved to a different location.
- Adjust the leveling feet until the air bubble is centered within the circle on the level indicator.

WZA224-LC, WZA224-L, WZA523-L:

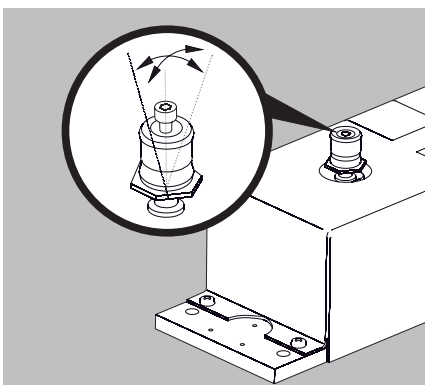

WZA224-LC, WZA224-L, WZA523-L:

Leveling the Load Receptor for the User-specific Transducer

- Remove the screw
- Position radially and level the load receptor
- Resecure the load receptor using the screw: torque 1 Nm
- Maximum permissible load on load receptor: see table on the next page
- Overload protection: available

⚠ Underweight protection: none

○ The load receptor can be removed completely when used with a user-specific transducer.

⚠ Make sure that the user-specific transducer is rigid.

WZA8202-L:

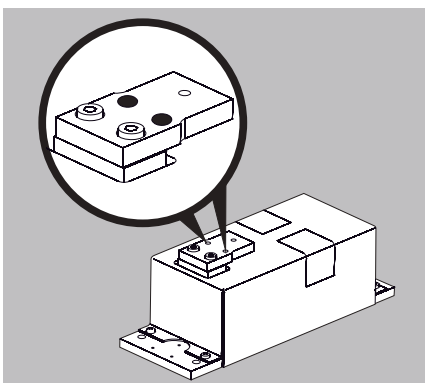

WZA8202-L: Securing a User-specific Transducer

- Screw the user-specific transducer to both threaded fasteners of the load receptor. For torque values, see table on next page "Maximum permissible load on load receptor."

⚠ Make sure the user-specific transducer is rigid, and is firmly attached to the load receptor.

⚠ Over load and underweight protection: not available

Maximum Permissible Load on Load Receptor:

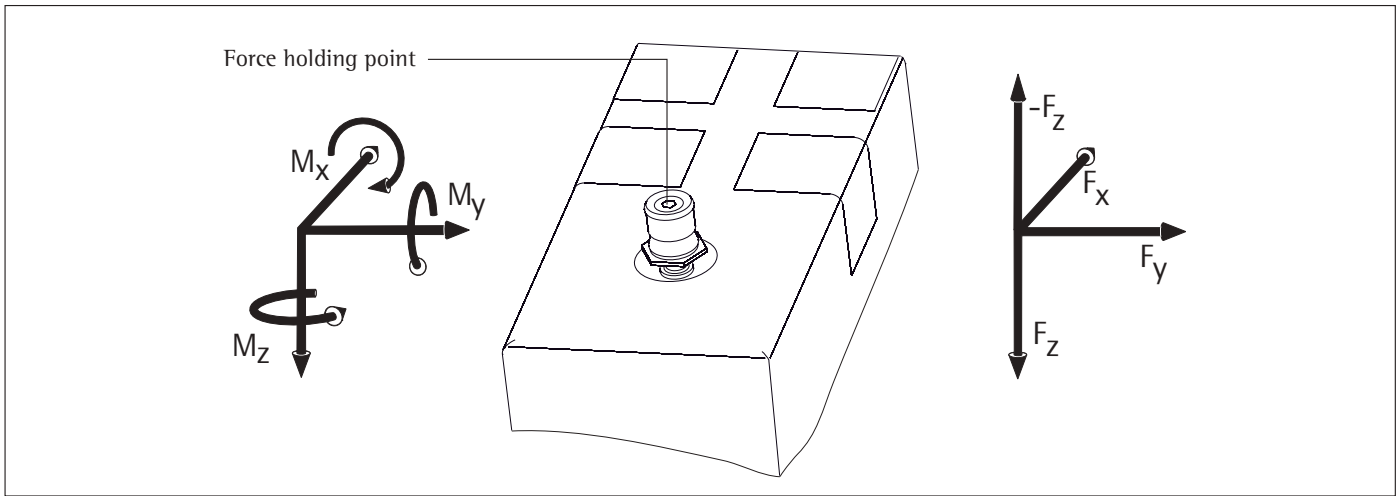

Model	Max. torque	Screwing torque	+ F _z	Max. force opposite to direction of load (-F _z)	Max. forces on force holding point F _x , F _y
WZA224-L, WZA224-LC	0.8 Nm	1 Nm	20 N	3 N	20 N
WZA54-L	0.1 Nm	0.5 Nm	2 N	2 N	2 N
WZA523-L	0.8 Nm	1 Nm	25 N	6 N	25 N
WZA8202-L	8 Nm	3 Nm	100 N	100 N	80 N

You can either have the maximum force or the maximum torque. If forces and torque occur simultaneously, then the sum of the percentage loads cannot exceed 100%. Higher loads may result in damage to the weigh cell.

Example:

Weigh cell with hook projecting out to the front. Torque M_y is the sum of the torque from the force of the weight W_{load}, the torque of any excess weight being exerted W_{ex} and the torque created by the intrinsic weight W_{hook} holding the weight. The force is F_z is equal to weight force F_{load}, plus the weight force of hook F_{hook} and the overload force F_{over}.

What is the maximum off-center overload force F_{over} for a WZA224-L with a load of M_{load} = 100 g and a hook length L of 100 mm for a standard weight of m_{hook} = 60 g?

The sum of the percentage weighing capacity of the forces and torques occurring may not exceed 100%.

$$1 = F_z / F_{zMax} + M_y / M_{Max}$$

$$F_z = F_{load} + F_{hook} / F_{over}$$

$$F_z = 1.57N + F_{over}$$

$$M_y = M_{load} + M_{hook} + M_{over}$$

$$M_y = 1.27 Nm + F_{over} \times 0.1 m$$

$$1 = (1.57 N + F_{over} / 20 N) + (0.127 Nm + F_{over} \times 0.1 m / 0.8 Nm)$$

$$F_{over} = 4.36 N$$

However, even very small forces can trigger the overload protection mechanism.

In general, load receptors should be constructed to be rigid to bending and twisting. We recommend testing to avoid unwanted feedback effects in the control loop. You should also take into account the effects of drafts and observe all instructions for analytical weighing.

Operation

Notes on Analytical Weighing with Weigh Cells

Handling of Samples and Containers

Samples should be acclimatized to the temperature of the weigh cell. This is the only way to avoid measurement errors caused by air buoyancy and fluctuations resulting from convection currents across the surface of the sample.

These negative effects increase as the volume and/or surface area of the sample increases. For this reason, the size of the tare container should be appropriate for the sample.

Samples and containers should not be touched by the operator's hands. This is because the hygroscopic effect of fingerprints and the effect of the hand's temperature can influence the measurement results.

Samples must be applied very carefully, whether manually (using a forceps) or automatically (by a robot or filling system).

When designing a draft shield device, steps must be taken to keep the increase in temperature within the weighing chamber to a minimum (e.g., using a bypass).

Weighing Electrostatically Charged Samples and Containers

Significant measuring errors can occur when electrostatically charged objects are weighed. This problem particularly involves samples that have extremely poor conductivity (glass, plastic, filters) since they can discharge electrostatic – i.e., friction-induced – charges through the weighing pan over a relatively long period of time only.

The result is a force acting between the charge on the sample and the permanently installed parts of the weigh cell. This causes the readout to fluctuate constantly.

Ionization can be applied to make the air around the sample conductive. This allows the charge to be compensated through the air, or discharged through the ground (grounded).

Aside from purely mechanical solutions (e.g., using a special weighing pan to shield the sample), bombarding the sample with ions of opposing polarity to neutralize the surface charge is one of the most effective methods for eliminating static electricity. Sartorius can provide ionization devices for installation in weighing systems.

The area around the weigh cell, like plastic parts, can also contain charges that negatively affect the accuracy of weighing results. Appropriate steps (grounding) taken in the design of a draft shield device can counteract such effects.

The weigh cell base plate and the electronics base plate should be grounded via the screw connections.

Weighing Magnetic or Magnetizable Samples

It is technically impossible to avoid using magnetizable materials for the production of weigh cells. This is primarily because the operating principle of high-resolution weigh cells is based on compensation of the load through magnetic forces.

When weighing magnetic or magnetizable samples or containers, interaction between the sample or container and the above-mentioned parts inside the weigh cell may have a distorting effect on the weighing results.

To keep such effects to a minimum, we recommend increasing the distance between the sample/container and the weighing system using a non-magnetic material. The force is reduced quadratically with the increase in distance.

Magnetizable or magnetized samples and the weigh cell itself interact with magnetic fields and magnetizable or magnetized parts in the area surrounding the weighing system. The system can be shielded from external magnetic fields to some extent using (soft magnetic) plates.

Effects of Drafts

Depending on the size of the load receptor and the sample, the effects of drafts may occur.

To minimize this effect, install a draft shield for protection.

Protect the weigh cell from drafts.

Calibration/Adjustment

Calibration/adjustment can be performed as follows:

- Using control commands sent by the CAS-Suite configuration software from Sartorius, installed on a computer (see page 22 for the commands)

or

- Using the optional YAC01ED control unit

Below-Cell Weighing

A port for a below-cell weighing hook is located on the bottom of the weigh cell (not model WZA54-L).

WZA224-L, WZA224-LC, WZA523-L:

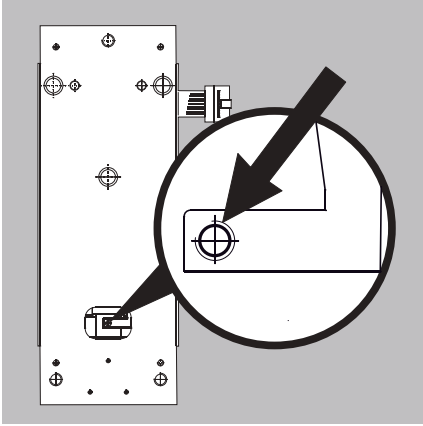

- **Models WZA224-L, WZA224-LC and WZA523-L:**
Carefully install the customer-specific hook.
Threaded fastener for hook: M3
Maximum torque: 0.8 Nm. Overload protection available.
- ⚠ Maximum screw installation depth: do not exceed 5 mm!
Otherwise no underweight protection.

WZA8202-L:

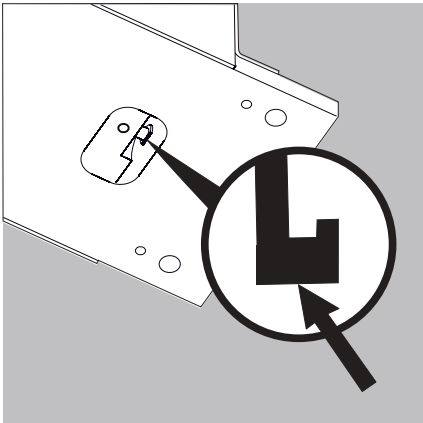

- **Model WZA8202-L:**
Hang below-cell weighing hook in the holder or screw into the M3 thread next to it.
- ⚠ Model WZA8202-L: no overload and underweight protection available.
- Install a draft shield if necessary.

Operation with the Optional YAC01ED Display and Control Unit

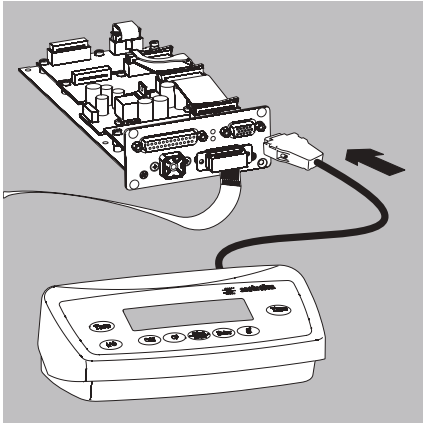

Connect the display and control unit to the weigh cell electronic unit using the supplied cable. Connection cable: 1 meter long with 15-pin D-Sub plug and socket. Pin 15 is not assigned.

Overview of Display and Control Panel

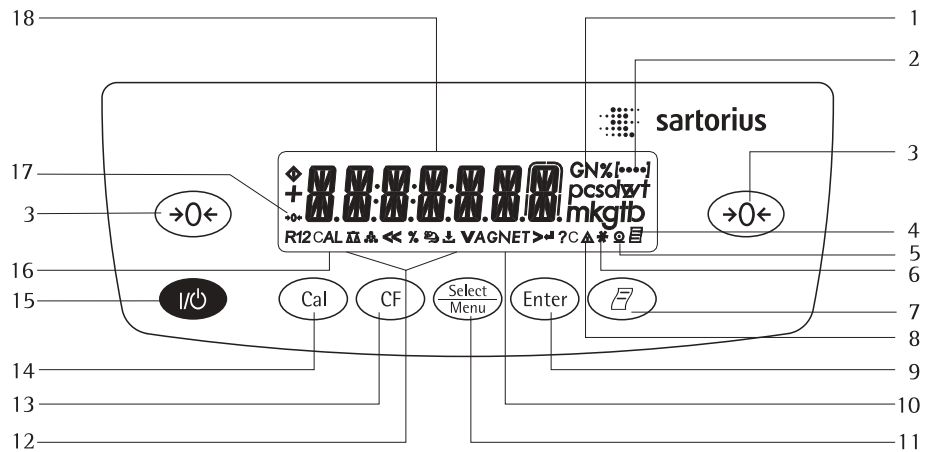

Position	Description
1	Weight units
2	Displays the menu level
3	Tare/Zero
4	Symbol for "GLP printing mode active"
5	Symbol for "Printing active"
6	Application program active
7	Manual data output: Press this key to send readout values to the built-in data interface.
8	Labeling: not a weight value
9	Start an application program
10	Display: Gross and net value
11	Select an application program Open the operating menu
12	Symbols for an active application (Δ, ∙, %, ⊞, ↓, A, C)



Position	Description
13	Clear Function This key is generally used to cancel functions: - Quit application program - Cancel calibration/adjustment routine Exit menu
14	Start the calibration/adjustment routine
15	On/off switch
16	Display: calibration/adjustment function
17	Symbols for zero range (verified models only)
18	Weight value displayed in selected weight unit
Symbol:	
<<	Exit menu
<	One menu level higher
V	Set menu item
>	Select the next sub-item within a menu level
↵	Confirm menu item

Basic Weighing Function

Characteristics

- Taring the weigh cell
- Print weight value

Preparation





- Switch on the weigh cell:
Press the  key
- Tare the balance/scale if necessary:
Press the  key
- If necessary, change the configuration settings:
see "Configuration" on the next page
- If desired, load the factory settings:
see "Configuration" on the next page

Additional functions:

- Switching off the weigh cell:
Press the  key

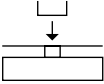
Example

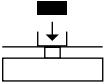
Determine a weight value

Step	Press key	Display/Printout
1. Switch on the weigh cell Self-test runs, followed by automatic initial tare function.		0.0 g
2. Place container on weighing pan (in this example 11.5 g).		+ 11.5 g
3. Tare the weigh cell		0.0 g
4. Place sample in container (in this example 132 g).		+ 132.0 g
5. Print weight value (in this example 22 characters)		N + 132.0 g

Configuration (Operating Menu)

Purpose

The weigh cell is configured at the factory. In Setup, you can configure the weigh cell, i.e. adapt it to individual requirements.

Characteristics

Parameters are combined into the following groups (1st menu level):

1. Weigh cell functions
 - Interface
 - Record (print)
 - Extra functions
2. Application Programs¹⁾
3. Input
4. Information
5. Language setting

Factory Settings for the Parameters

The factory-set configurations are identified by an "o" in the list below.

Customer-specific settings can be configured on request.

Preparation







- Using the CAS-Suite configuration software from Sartorius installed on a PC, you can process the operating menu parameters as follows:
 - Read
 - Modify
 - Print
 - Save

or

Using the optional YAC01ED control unit

Configuring of the weigh cell, i.e., adapting it to individual requirements.











Functions of the Keys in the Menu:

Symbol displayed	Key	Object
V		Scroll through menu items
>		One menu level lower (with cursor right up to 4 menu levels)
↵		Confirm menu item
<<		Save settings and exit menu from any position
<		Save settings and exit menu:
<		One menu level higher (left cursor)
[••••]		Indicates menu level

¹⁾ Detailed instructions for the available application programs can be found in the "ED..., Extend ED Model Range" operating instructions, which can be downloaded from the internet at www.sartorius.com.
Go to Service Center → Downloads.

Menu Navigation

Example: Setting the Language

Step	Press key	Display
1. Open the menu: Display the 1st menu item in the weighing mode	 long	APPLIC.
2. Scroll upward within the menu level; After the last menu code, the first code is displayed again (scroll)	Repeatedly press 	INPUT ... LANGUAG.
3. Select next menu level (scrolls to the right)	Press repeatedly 	ENGLISH °
4. Change setting: Select the menu item by scrolling up		ENGLISH
5. Confirm setting: “o” indicates the menu item you have set		GERMAN °
6. Go back to the previous menu level (from menu level 4)		LANGUAGE
○ If required, select further menu items	 , 	
7. Save setting and exit the menu	Press repeatedly 	
or		
○ Exit menu without saving changes		
> Restart your application		0.0 g

Menu Structure (Overview)







Level 1 [●]	Level 2 [●●]	Level 3 [●●●]	Codes	
SETUP	BAL.SCAL. (Weigh cell functions)	AMBIENT conditions (adapt filter)	1. 1. 1.	
		APP.FILT. Application filter	1. 1. 2.	
		STAB.RNG. Stability range	1. 1. 3.	
		STAB.DLY Stability delay	1. 1. 4.	
		TARING Taring	1. 1. 5.	
		AUTOZER. Auto zero	1. 1. 6.	
		WT.UNIT Basic weight unit	1. 1. 7.	
		DISPLAY Display accuracy	1. 1. 8.	
		CAL./ADJ. Function of the  key	1. 1. 9.	
		CAL.ROUTINE	1. 1.10.	
		CAL.UNIT Weight unit for calibration	1. 1.11.	
		ZERO.RNG. Zero range	1. 1.12.	
		ZERO.ON Zero at Power On	1. 1.13.	
		ON.TARE Tare/zero at power:	1. 1.14.	
	INTERF. Interface	BAUDrate	1. 5. 1.	
		PARITY Parity	1. 5. 2.	
		STOPBIT Number of stop bits	1. 5. 3.	
		HANDSHK. Handshake mode	1. 5. 4.	
		DATABIT Number of data bits	1. 5. 5.	
		DAT.REC. SBI (ASCII) or printout	1. 5. 6.	
	DAT.REC.(Print)	PRINT (manual/automatic)	1. 6. 1.	
		STOP automatic printing	1. 6. 2.	
		AUT.CYCL. Time-dependent autom. Print	1. 6. 3.	
		TAR./PRT. Tare bal./scale after ind. print	1. 6. 4.	
		PRT.INIT. Printout of appl. parameters	1. 6. 5.	
		FORMAT Line format for printout	1. 6. 6.	
		GLP ISO/GLP-compliant printout	1. 6. 7.	
		TIME: 12h/24h	1. 6. 8.	
		DATE format	1. 6. 9.	
	EXTRAS (Additional functions)	MENU Read only/Can edit	1. 8. 1.	
		HORN Acoustic Signal	1. 8. 2.	
		KEYS (Keypad)	1. 8. 3.	
		EXT.KEY External switch function	1. 8. 4.	
		ONMODE Power-on mode	1. 8. 5.	
		BACKLIT Display backlighting	1. 8. 6.	
	RESET	MENU Factory settings	1. 9. 1.	
	APPLIC. Application programs	WEIGH	2. 1.	
		UNIT Toggle	2. 2. 2.	
		COUNTING	RESOLUT. ion	2. 3. 1.
			REF.UPDT. Automatic reference updating	2. 3. 2.
		PERCENT weighing	DEC.PLCS Decimal places	2. 4. 1.
		NET.TOT. Net total	COMP.PRT. Printout of components	2. 5. 1.
		TOTAL Totalizing	COMP.PRT. Printout of components	2. 6. 1.
		ANIM.WG Animal weighing	ACTIVITY. Animal activity	2. 7. 1.
			START	2. 7. 2.
CALC. Calculation		METHOD (Operator)	2. 8. 1.	
	DEC.PLCS Decimal places	2. 8. 2.		
	DEC.PLCS Decimal places	2. 9. 1.		
DENSITY determination				
INPUT Input	IDNO.	ID input; max. 7 characters	3. 1.	
INFO Information	VERSION, SER.NO., MODEL	Displays software vers., serial no., model	4. 1./2./3.	
LANGUAGE (LANGUAGE.)	ENGLISH (factory setting)		5. 1.	
	DEUTSCH (German)		5. 2.	
	FRANC.ais (French)		5. 3.	
	ITAL. (Italian)		5. 4.	
	ESPAÑOL (Spanish)		5. 5.	
	РУССКИЙ (Russian)		5. 6.	
	POLSKI (Polish)		5. 7.	
	CODES Menu shows codes (not texts)		5. 8.	

Parameter Settings: Overview

o = Factory setting; √ = User-defined setting

Level 1 [•]	Level 2 [••]	Level 3 [•••]	Level 4 [••••]	Code	
1.) SETUP	BAL.SCAL Weigh cell functions	AMBIENT conditions (Filter adaptation)	o V.STABLE Very stable conditions	1. 1. 1. 1	
			o STABLE Stable conditions	1. 1. 1. 2	
			o UNSTABL Unstable conditions	1. 1. 1. 3	
			o V.UNSTBL Very unstable conditions	1. 1. 1. 4	
		APP.FILT. Application filter	o FINAL.RD Final readout mode	1. 1. 2. 1	
			o FILLING Filling mode	1. 1. 2. 2	
			o REDUC. Reduced	1. 1. 2. 3	
			o OFF	1. 1. 2. 4	
		STAB.RNG. Stability range	o 1/4 DIG.it (digit)	1. 1. 3. 1	
			o 1/2 DIG.it (digit)	1. 1. 3. 2	
			o 1 DIG.it (digit)	1. 1. 3. 3	
			o 2 DIG.it (digits)	1. 1. 3. 4	
			o 4 DIG.it (digits)	1. 1. 3. 5	
			o 8 DIG.it (digits)	1. 1. 3. 6	
		STAB. Stability delay	o No delay	1. 1. 4. 1	
			o Short delay	1. 1. 4. 2	
			o Medium delay	1. 1. 4. 3	
			o Long delay	1. 1. 4. 4	
		TARING Taring	o W/O STB W/o stability	1. 1. 5. 1	
			o W/ STB After stability	1. 1. 5. 2	
		AUT.ZERO Auto zero	o OFF	1. 1. 6. 1	
			o ON	1. 1. 6. 2	
		WT.UNIT Basic weight unit	o Free unit	1. 1. 7. 1	
			o Gram	1. 1. 7. 2	
			o Units: Kilogram to Newton	1. 1. 7. 3 to 1. 1. 7.23	
		BASIC ACCURACY Display accuracy	o ALL	1. 1. 8. 1	
			o MINUS 1 One level lower	1. 1. 8. 2	
			o Increment of the measured values one level lower	1. 1. 8. 3	
			o Increment of the measured values two levels lower	1. 1. 8. 4	
			o Increment of the measured values three levels lower	1. 1. 8. 5	
			o INERM. 1 Last digit single increment	1. 1. 8. 6	
			o Resolution by a factor of 10	1. 1. 8. 8	
			CAL./ADJ. Function of the (Cal) key	o EXT.CAL. External calibr./adjustment with factory-set weight	1. 1. 9. 1
		o CAL.EUSR. External calibr./adjustment with user-defined weight		1. 1. 9. 3	
		o CAL.INT. Internal calibr./adjustment		1. 1. 9. 4	
		o LINE.EXT. External linearization with factory-set weights		1. 1. 9. 6	
		o LINE.USR. External linearization with user-defined weights		1. 1. 9. 7	
		o SET.PRE. Setting the preload		1. 1. 9. 8	
		o CLR.PRELOAD Clear preload		1. 1. 9. 9	
		o BLOCKE (Cal) blocked		1. 1. 9. 11	
		CAL.ROUTINE		o SEQUENCE adjustment	1. 1. 10. 1
				o CAL.ADJ. Adjustment as needed	1. 1. 10. 2
		CAL.UNIT Weight unit for calibration	o GRAM	1. 1. 11. 1	
			o KILOGR. Kilograms	1. 1. 11. 2	
			o POUNDS	1. 1. 11. 3	
		ZERO.RNG. Zero range	o DEFAULT. (factory-set)	1. 1. 12. 1	
			o 2 PERC.ent	1. 1. 12. 2	
o 5 PERC.ent	1. 1. 12. 3				
o 10 PERC.ent	1. 1. 12. 4				
INT.ZERO Power On	o Zero at power-on default (factory-set)	1. 1. 13. 1			
	o Initial zero 2%/max. cap	1. 1. 13. 2			
	o Initial zero 5%/max. cap	1. 1. 13. 3			
	o Initial zero 10%/max. cap	1. 1. 13. 4			
	o Initial zero 20%/max. cap	1. 1. 13. 5			
	o Initial zero 50%/max. cap	1. 1. 13. 6			
	o Initial zero 100%/max. cap	1. 1. 13. 7			
ON.TARE (Tare/Zero at Power/ Zero-setting range)	o OFF	1. 1. 14. 1			
	o ON	1. 1. 14. 2			
Output rate	o Normal	1. 1. 15. 1			
	o Fast (five times faster)	1. 1. 15. 2			

Level 1 [•]	Level 2 [••]	Level 3 [•••]	Level 4 [••••]	Code
SETUP	INTERF. Interface	BAUDrate	<input type="radio"/> 600	1. 5. 1. 3
			<input type="radio"/> 1200	1. 5. 1. 4
<input type="radio"/> 2400			1. 5. 1. 5	
<input type="radio"/> 4800			1. 5. 1. 6	
<input type="radio"/> 9600			1. 5. 1. 7	
<input type="radio"/> 19200			1. 5. 1. 8	
<input type="radio"/> 38400			1. 5. 1. 9	
PARITY Parity			<input type="radio"/> ODD	1. 5. 2. 3
			<input type="radio"/> EVEN	1. 5. 2. 4
		<input type="radio"/> NONE (no parity)	1. 5. 2. 5	
STOP BIT Number of stop bits		<input type="radio"/> 1 STOP	1. 5. 3. 1	
	<input type="radio"/> 2 STOP	1. 5. 3. 2		
HANDSHK. Handshake Operating mode	<input type="radio"/> SOFTWARE	1. 5. 4. 1		
	<input type="radio"/> HARDWARE	1. 5. 4. 2		
	<input type="radio"/> NONE	1. 5. 4. 3		
DATA BIT Number of data bits	<input type="radio"/> 7 BITS	1. 5. 5. 1		
	<input type="radio"/> 8 BITS	1. 5. 5. 2		
DAT.REC. Com- munication mode	<input type="radio"/> Sartorius SBI (ASCII)	1. 5. 6. 1		
	<input type="radio"/> PRINTER (GLP-compliant record)	1. 5. 6. 2		
	<input type="radio"/> Sartorius XBPI	1. 5. 6. 4		
DAT.REC. (Printout)	PRINT (manual/ automatic)	<input type="radio"/> MANUAL WITHOUT stability	1. 6. 1. 1	
		<input type="radio"/> MAN.WITH. stability	1. 6. 1. 2	
		<input type="radio"/> AUTO.W/O. stability	1. 6. 1. 3	
		<input type="radio"/> AUT.WITH stability	1. 6. 1. 4	
		<input type="radio"/> LB.CHNGE Autom. after load change	1. 6. 1. 5	
	STOP autom. printing	<input type="radio"/> OFF Not possible	1. 6. 2. 1	
		<input type="radio"/> ON Cancel with 	1. 6. 2. 2	
	AUT.CYCL. Time-dependent autom. printing	<input type="radio"/> EACHVAL (1 display update)	1. 6. 3. 1	
		<input type="radio"/> AFTR.2 (2 display updates)	1. 6. 3. 2	
	TAR./PRT. Tare bal./scale after ind. print	<input type="radio"/> OFF	1. 6. 4. 1	
		<input type="radio"/> ON	1. 6. 4. 2	

Level 1 [•]	Level 2 [••]	Level 3 [•••]	Level 4 [••••]	Code
SETUP	DAT.REC. printout (Printout)	PRT.INIT. Print- out of application parameters	OFF	1. 6. 5. 1
			o ALL All parameters MAINPAR. Main parameters	1. 6. 5. 2 1. 6. 5. 3
		FORMAT Line format for printout	o 16.CHAR. characters (w/o ID)	1. 6. 6. 1
			o 22.CHAR. characters (w/ ID)	1. 6. 6. 2
			o 2NDLINE with date/time	1. 6. 6. 3
		GLP printout As ISO/GLP-com- pliant Printout	o OFF	1. 6. 7. 1
			o CAL.-ADJ. Only for calib./adj.	1. 6. 7. 2
			o ALWAYS on	1. 6. 7. 3
		TIME	o 24H display	1. 6. 8. 1
			o 12H display "AM/PM"	1. 6. 8. 2
	DATE	o DD.MMM.YY format	1. 6. 9. 1	
		o MMM.DD.YY format	1. 6. 9. 2	
	EXTRAS (Additional functions) 1. 8. 2. 2	MENU	o CANEDIT	1. 8. 1. 1
			o RD.ONLY Read only	1. 8. 1. 2
		HORN Acoustic Signal	o OFF	1. 8. 2. 1
			o ON	
		KEYS (Keypad)	o FREE	1. 8. 3. 1
			o BLOCKE D	1. 8. 3. 2
		EXT.KEY External switch function	o PRINT key 	1. 8. 4. 1
			o Z/TARE  key	1. 8. 4. 2
			o CAL.  key	1. 8. 4. 3
			o SELECT  key	1. 8. 4. 4
	o CF  key		1. 8. 4. 5	
o ENTER  key BLOCKE D Key locked	1. 8. 4. 6 1. 8. 4. 9			
ON MODE Power-on mode	o OFF/ON Off/on/standby	1. 8. 5. 1		
	o STANDBY On/standby	1. 8. 5. 2		
	o AUTO ON Auto on	1. 8. 5. 3		
BACKLIT Display backlighting	o OFF	1. 8. 6. 1		
	o ON	1. 8. 6. 2		
RESET Reset menu	MENU Factory settings	o YES Restore fcty. settings	1. 9. 1. 1	
		o NO Do not restore settings	1. 9. 1. 2	

Application Program Configuration:

Level 1 [•]	Level 2 [••]	Level 3 [•••]	Level 4 [••••]	Code
APPLIC. Application programs 1)	WEIGH			2. 1.
	UNIT Toggling	2.WT.UNIT	<input type="radio"/> Free unit <input type="radio"/> Gram Units: Kilogram to Newton	2. 2. 1. 1 2. 2. 1. 2 2. 2. 1. 3 to 2. 2. 1. 23
		BASIC ACCURACY Display accuracy	<input type="radio"/> ALL <input type="radio"/> MINUS 1 One level lower <input type="radio"/> Increment of the measured values one level lower <input type="radio"/> Increment of the measured values two levels lower <input type="radio"/> Increment of the measured values three levels lower <input type="radio"/> INCRM. 1 Last digit single increment	2. 2. 2. 1 2. 2. 2. 2 2. 2. 2. 3 2. 2. 2. 4 2. 2. 2. 5 2. 2. 2. 6
	COUNTING	RESOLUT.	<input type="radio"/> DISP.DIG. Display accuracy <input type="radio"/> 10 FOLD 10 times > disp.	2. 3. 1. 1 2. 3. 1. 2
		REF.UPDT. Auto. Reference updating	<input type="radio"/> OFF <input type="radio"/> AUTOM.atically	2. 3. 2. 1 2. 3. 2. 2
	PERCENT Weighing in Percent	DEC.PLCS Decimal places	<input type="radio"/> NONE No decimal places <input type="radio"/> 1 DEC.PL. 1 decimal place <input type="radio"/> 2 DEC.PL. 2 decimal places <input type="radio"/> 3 DEC.PL. 3 decimal places	2. 4. 1. 1 2. 4. 1. 2 2. 4. 1. 3 2. 4. 1. 4
	NET.TOT. Net total	COMP.PRT. Component printout	<input type="radio"/> OFF <input type="radio"/> ON	2. 5. 1. 1 2. 5. 1. 2
	TOTAL Totalizing	COMP.PRT. Component printout	<input type="radio"/> OFF <input type="radio"/> ON	2. 6. 1. 1 2. 6. 1. 2
	ANIM.WG Animal weighing	ACTIVITY. Animal activity	<input type="radio"/> CALM (fluct.: 2% of test obj.) <input type="radio"/> ACTIVE (fluct.: 5% of test obj.) <input type="radio"/> V.ACTIVE (fluct.: 20% of test obj.)	2. 7. 1. 1 2. 7. 1. 2 2. 7. 1. 3
		START	<input type="radio"/> MANUAL <input type="radio"/> AUTO. Automatic	2. 7. 2. 1 2. 7. 2. 2
	CALC. Calculation	METHOD (operator)	<input type="radio"/> MUL. Multiplier <input type="radio"/> DIV. Divisor	2. 8. 1. 1 2. 8. 1. 2
		DEC.PLCS Decimal places	<input type="radio"/> NONE No decimal places <input type="radio"/> 1 DEC.PL. 1 decimal place <input type="radio"/> 2 DEC.PL. 2 decimal places <input type="radio"/> 3 DEC.PL. 3 decimal places	2. 8. 2. 1 2. 8. 2. 2 2. 8. 2. 3 2. 8. 2. 4
	DENSITY determination	DEC.PLCS Decimal places	<input type="radio"/> NONE No dec. places <input type="radio"/> 1 DEC.PL. 1 decimal place	2. 9. 1. 1 2. 9. 1. 2

1) If you need more detailed information on application programs:
Please contact your local Sartorius dealer.

Configuration (Setup)

Purpose

Weigh cells are equipped with an interface port for connection to a computer or other peripheral device.

PC

You can connect a computer to change, start and/or monitor functions and application programs.

Characteristics

Type of interface: Serial interface
 Interface operating mode: Full duplex
 Level: RS-232
 Transmission rate:
 600, 1200, 2400, 4800, 9600, 19,200 and 38,400 baud
 Parity: Odd, even, none
 Number of data bits: 7 or 8 bits
 Character transmission:
 Start bit, 7-bit ASCII, parity,
 1 or 2 stop bits
 Handshake:
 For 2-wire interface:
 Software (XON/XOFF) or none
 For 4-wire interface:
 Hardware (CTS/DTR) or none
 Data output of balance/scale:
 16 or 22 characters

Factory Setting of the Parameters

Transmission rate:
 1200 baud (Code 1. 5. 1. 4)
 Parity: $\overline{\text{ODD}}$ Odd (1. 5. 2. 3)
 Stop bits: 1.5STOPbit (1. 5. 3. 1)
 Handshake:
 HANDBSK. Hardware handshake (1. 5. 4. 2)
 Communication mode: $\overline{\text{SBI}}$ (1. 5. 6. 1)
 Printing: MANWITH Manual after stability (1. 6. 1. 2)

Preparation

See "Pin Assignments" and "Pin Assignment Chart"

Operation

Output Format with 16 Characters (Compatibility with Current Weigh Cells)

Display segments that are not activated are output as spaces.

The type of character that can be output depends on the character's position:

Position	1	2	3	4	5	6	7	8	9	10	11	12	13	14	15	16
	+			A	A	A	A	A	A	A	*	E	E	E	CR	LF
or	-				*	*	*		
or	*	*	*	*	*	*	*	*	*	*						

*: Space
 A: Displayed characters
 E: Unit symbol
 CR: Carriage return
 LF: Line feed
 .: Decimal point

Special Codes

Position	1	2	3	4	5	6	7	8	9	10	11	12	13	14	15	16
	*	*	*	*	*	*	*	*	*	*	*	*	*	*	CR	LF
or							H	i	g	h						
or							L	o	w							
or				C	a	l	.	E	x	t	.					

*: Space
 Cal. Ext.: Adjustment, external
 High: Overload
 Low: Underweight

Error message

Position	1	2	3	4	5	6	7	8	9	10	11	12	13	14	15	16
				E	r	r	*	#	#	#	*	*	*	*	CR	LF
				A	P	P	.	E	R	R ¹⁾	*	*	*	*	CR	LF
				D	I	S	.	E	R	R ¹⁾	*	*	*	*	CR	LF
				P	R	T	.	E	R	R ¹⁾	*	*	*	*	CR	LF

*: Space
 # # #: Error code number

1) For cause and solution, please refer to the "Troubleshooting Guide"

Example: Output of the weight value + 123.56 g

Position	1	2	3	4	5	6	7	8	9	10	11	12	13	14	15	16
	+	*	*	*	1	2	3	.	5	6	*	g	*	*	CR	LF
	+	*	*	1	2	3	.	5	[6]¹)	g	*	*	CR	LF

- Position 1: Plus or minus sign or space
- Position 2: Space
- Position 3 - 10: Weight value with decimal point; leading zeros are output as spaces.
- Position 11: Space
- Position 12 - 14: Characters for unit of measure or space
- Position 15: Carriage return
- Position 16: Line feed

Output Format with 22 Characters (Compatibility with Current Weigh Cells)

When data is output with an ID code, the 6-character code precedes the 16-character string described above. These six characters identify the subsequent value.

1	2	3	4	5	6	7	8	9	10	11	12	13	14	15	16	17	18	19	20	21	22
K	K	K	K	K	K	+	*	A	A	A	A	A	A	A	A	*	E	E	E	CR	LF
	*	*	*	*	*	-			*	*	*		
						*		*	*	*	*	*	*	*	*						

- K: ID code character
- *: Space
- A: Displayed characters
- E: Unit symbol
- CR: Carriage return
- LF: Line feed

Example:

1	2	3	4	5	6	7	8	9	10	11	12	13	14	15	16	17	18	19	20	21	22	
N						+				1	2	3	.	5	6	*	g	*	*	CR	LF	
N						+				1	2	3	.	5	[6]¹)	g	*	*	CR	LF

SBI mode:

When the SBI mode is active (menu code 1. 5. 6. 1), non-verified display digits are not automatically marked. Please take the corresponding measures or adjust the settings on the peripheral device.

Special Codes

1	2	3	4	5	6	7	8	9	10	11	12	13	14	15	16	17	18	19	20	21	22	
S	t	a	t	*	*	*	*	*	*	*	*	*	*	*	*	*	*	*	*	*	CR	LF
											H	i	g	h								
											L	o	w									
											C	a	l	.	E	x	t	.				

- *: Space
- Cal. Ext.: Adjustment, external
- High: Overload
- Low: Underweight

Error message

1	2	3	4	5	6	7	8	9	10	11	12	13	14	15	16	17	18	19	20	21	22
S	t	a	t	*	*	*	*	*	E	R	R	*	#	#	#	*	*	*	*	CR	LF
S	t	a	t	*	*	*	*	*	A	P	P	.	E	R	R ¹)	*	*	*	*	CR	LF
S	t	a	t	*	*	*	*	*	D	I	S	.	E	R	R ¹)	*	*	*	*	CR	LF
S	t	a	t	*	*	*	*	*	P	R	T	.	E	R	R ¹)	*	*	*	*	CR	LF

- *: Space
- # # #: Error code number

¹) For cause and solution, please refer to the "Troubleshooting Guide"

Commands (Data Input Format Compatible with Current Weigh Cells)

The computer connected via the data port can send commands to the weigh cell for controlling functions. The commands sent are control commands and may have different formats. Control commands consist of up to 13 characters. Each character must be transmitted according to the settings configured in the operating menu for data transmission.



Formats for Control Commands

Format 1:	Esc	!	CR	LF		
Format 2:	Esc	!	#	_	CR	LF





Esc: Escape (optional)
 !: Command character
 _: Underline

CR: Carriage return
 LF: Line feed (optional)

Command character

Format 1:	Meaning
!	Meaning
K	Ambient conditions: very stable
L	Ambient conditions: stable
M	Ambient conditions: unstable
N	Ambient conditions: very unstable
O	Block keys
P	Key  (print, auto print; activate or block) ¹⁾
Q	Acoustic signal
R	Unblock keys
S	Restart Self-test
T	Tare Zero: Key " 
U	Tare
V	Zero
W	Calibrate Adjust depending on menu setting
Z	Perform internal calibration/adjustment ²⁾

Command character

Format 2:	Meaning
!#	Meaning
f0_	Function key 
f1_	Function key  Calibrate Adjust (depending on the menu setting)
f2_	Function key 
s1_	With »s8_« compatibility: Toggle selection in steps of 1 With »s9_« compatibility: Adjust according to menu setting
s2_	Activate parameter mode (selection)
s3_	Key 
s8_	Compatibility: Consistent with current weigh cells (from 2013)
s9_	Compatibility: Consistent with older weigh cells (previous models)
x0_	Perform internal adjustment
x1_	Print model
x2_	Print serial no.
x3_	Print software version

¹⁾ When initiating the print command, the data output rates may differ: see table on next page.

²⁾ Only on models with internal weight circuit

Synchronization

During data communication between the weigh cell and a connected device (computer), messages consisting of ASCII characters are transmitted via the interface. For error-free data exchange, parameters for baud rate, parity, handshake mode and character format must be identical for both units.

You can set these parameters in the Setup menu so that they match those of the connected device. You can also define parameters in the balance/scale to make data output dependent on various conditions. These conditions are described under each of the application program descriptions.
No errors are generated just because no peripheral device is connected to an interface port (open data port).

Handshake

The weigh cell interface (Sartorius Balance Interface = SBI) has transmit and receive buffers. You can define the different handshake parameters in the Setup menu of your weigh cell:

- Hardware handshake (CTS/DTR)
- Software handshake (XON, XOFF)
- No handshake

Hardware Handshake

When hardware handshake is configured on a 4-wire interface, 1 more character can be transmitted after CTS.

Software Handshake

The software handshake is controlled via XON and XOFF. When a device is switched on, XON must be transmitted to enable any connected device to communicate.

Data Output by Print Command

The print command can be transmitted by pressing  or by a software command (Esc P).

Automatic Data Output

Activate the "Auto Print" operating mode to have data output to the interface port without a print command. You can have synchronized data output automatically at defined display update intervals, with or without the stability parameter. The length of a print interval depends on the operating menu settings for *AMBIENT* (ambient conditions, menu code 1. 1. 1. x) and *AUT.EYCL.* (time-dependent autom. printing, menu code 1. 6. 3. x).
If you activate the auto print setting, data will be transmitted immediately the moment you turn on the balance/scale. In the operating menu, you can define whether automatic printing can be stopped and started by pressing the "Print" key or using the interface.

Data Output Rates – Values per Second

Environmental conditions (filter adaptation)	XBPI / SBI "Auto print"	
Very stable (1.1.1.1)	20	20
Stable (1.1.1.2)	10	10
Unstable (1.1.1.3)	5	5
Very unstable (1.1.1.4)	2.5	2.5

Data Interface: Compatibility with Older Weigh Cells (Previous Models)

Once command »ESC s9_« has been sent, data input and data output behave as in the earlier Sartorius WZ-/WZA weigh cells (previous models).

Data Output Format

In operating mode »SBI«, 16 characters are printed out.

Example:

+ 253 pcs

Data Output Format with 16 Characters

Characters that are displayed blank are printed as spaces. Display values without a decimal point are output without a decimal point.

The type of character that can be output depends on the character's position:

Normal Operation

Position	1	2	3	4	5	6	7	8	9	10	11	12	13	14	15	16
	+	A	A	A	A	A	A	A	A	A	*	E	E	E	CR	LF
or	-		*	*	*		
or	*	*	*	*	*	*	*	*	*	*						

*: Space

A: Digits of measurement value

E: Unit symbol

CR: Carriage return

LF: Line feed

Special Codes

Position	1	2	3	4	5	6	7	8	9	10	11	12	13	14	15	16
	*	*	*	*	*	*	-	-	*	*	*	*	*	*	CR	LF
or							H	H								
or							L	L								
or							C									

*: Space
 - -: Final readout
 H: Overload
 H H: Overload in checkweighing
 (Function is only available during operation with following peripheral devices:
 Optional display unit or software YAD011S)
 L: Underweight
 L L: Underweight in checkweighing
 C: Adjustment

Error Messages

Position	1	2	3	4	5	6	7	8	9	10	11	12	13	14	15	16
	*	*	*	E	r	r	*	#	#	#	*	*	*	*	CR	LF

*: Space
 # # #: Error number

Example: Output of the weight value + 1255.7 g

Position	1	2	3	4	5	6	7	8	9	10	11	12	13	14	15	16
	+	*	*	*	1	2	5	5	.	7	*	g	*	*	CR	LF

Position 1: Plus +, minus -, or space
 Position 2: Space
 Position 3 - 10: Weight value with decimal point; leading zeros are printed as spaces
 Position 11: Space
 Position 12 - 14: Characters for unit of measure or space
 Position 15: Carriage return
 Position 16: Line feed

Data Input Format

A computer connected via the data port can send commands to the device to control device functions.

The commands sent are control commands and may have different formats. Control commands have up to 26 characters. Each of these characters must be sent based on the setup configuration for data transmission.

Formats for Control Commands

Format 1:	Esc	!	CR	LF		
Format 2:	Esc	!	#	_	CR	LF

Esc: Escape
 #: Number
 _: Underscore (ASCII: 95)
 CR: Carriage return (optional)
 LF: Line feed (optional)
 max: Depending on the command character, i.e. parameter: The entry is truncated after the max. length, and not rejected as when entered via the keyboard

Format 1 (e.g., ESC K)

!	Meaning
K	Filter adjustment: Very stable conditions
L	Filter adjustment: Stable conditions
M	Filter adjustment: Unstable conditions
N	Filter adjustment: Very unstable conditions
O	Lock keys
Q	Acoustic signal (beep)
P	Print
R	Release keys
S	Restart
T	Tare and zero
Z	Internal adjustment

Format 2 (e.g., ESC f3_)

!#	Meaning
f1_	Calibrate or Adjust according to menu setting
f3_	Zero
f4_	Tare (without zeroing)
s1_	External adjustment
s3_	Function [CF]
x0_	Perform internal calibration
x1_	Print load cell type
x2_	Print load cell series no.
x3_	Load cell software version

Pin Assignment Chart

Female Interface Connector:

25-pin D-Submini (DB25S) with screw lock hardware

Required Male Connector (Recommended):

25-pin D-Submini, DB25S, with integrated shielded cable clamp and shield plate assembly (Amp type 826 985-1C) and fastening screws (Amp type 164 868-1)

⚠ Warning When Using Pre-wired RS-232 Connecting Cables:

The pin assignments in RS-232 cables purchased from other manufacturers may be incompatible with Sartorius weighing instruments. Be sure to check the pin assignments against the chart below before connecting the cable, and disconnect any lines identified differently from those specified by Sartorius (e.g., pin 6). Failure to do so may cause malfunction, damage or even completely ruin your balance/scale and/or peripheral device(s).

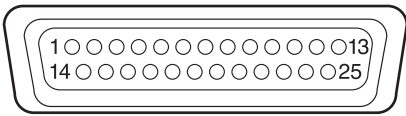

Pin Assignments:

- Pin 1: Signal Ground
- Pin 2: Data Output (TxD)
- Pin 3: Data Input (RxD)
- Pin 4: Internal Ground (GND)
- Pin 5: Clear to Send (CTS)
- Pin 6: Not used
- Pin 7: Internal Ground (GND)
- Pin 8: Internal Ground (GND)
- Pin 9: Not used
- Pin 10: Not used
- Pin 11: +12 V (operating voltage for Sartorius printer)
- Pin 12: Reset _ Out ¹⁾
- Pin 13: +5 V
- Pin 14: Internal Ground (GND)
- Pin 15: Universal remote switch
- Pin 16: Not used
- Pin 17: Not used
- Pin 18: Not used
- Pin 19: Not used
- Pin 20: Data Terminal Ready (DTR)
- Pin 21: Not used
- Pin 22: Not used
- Pin 23: Not used
- Pin 24: Not used
- Pin 25: +5 V

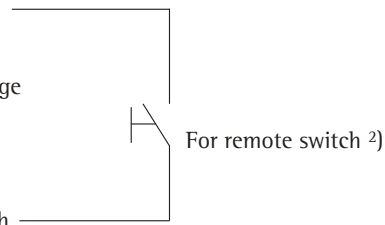

¹⁾ = Hardware restart

²⁾ = External switch function can be programmed in the Setup: *EXTRAS* : *EXT*.key (1.8.4.x)

Cabling Diagram

For connecting a computer or other peripheral device to the balance/scale using the RS-232C/V24 protocol and cable lengths of up to 15 m (approx. 50 ft).

No other pins of the balance/scale may be assigned!

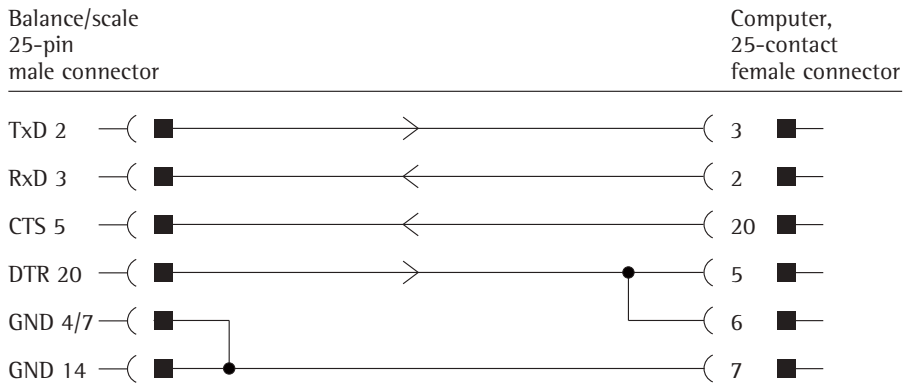
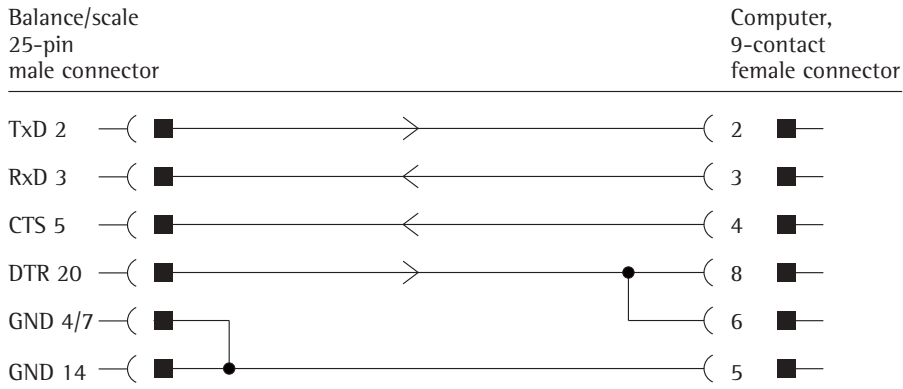

Cable type: AWG 24 specification

Models WZA...-L: Extension Cords between Weigh Cell and Electronics PCB

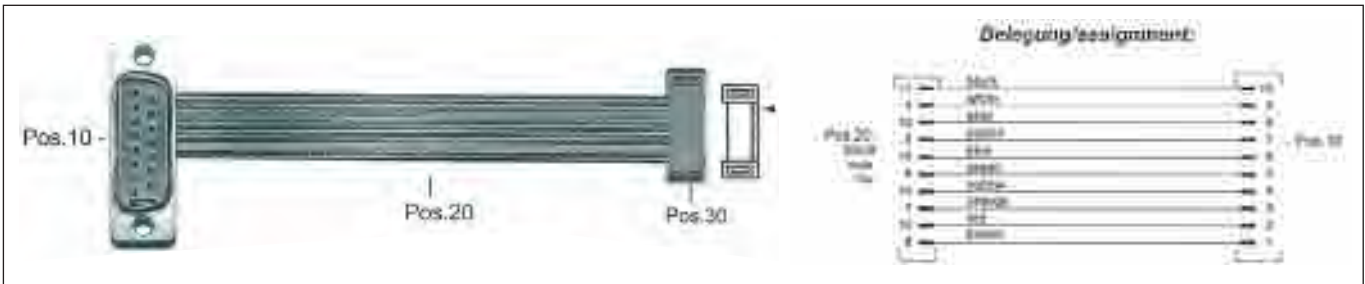

Pos.:	Name:	Manufacturer:	Manufacturer#:	Internal article #:	Cutting length:	Quantity:	Approvals/Comments:
10	Male connector, 15-pin, D-SUB IDC	free				1x	lowcost
20	Ribbon cable, 10 p. AWG28 color-coded	3M	3302-10	57001-368-01	500 mm	1x	UL-File#: E42769
30	Male connector, 10-pin, IDC	3M	4610-6051	010800		1x	UL-File#: E68080

Model WZA224-LC: Extension Cord between Weigh Cell and Electronics PCB

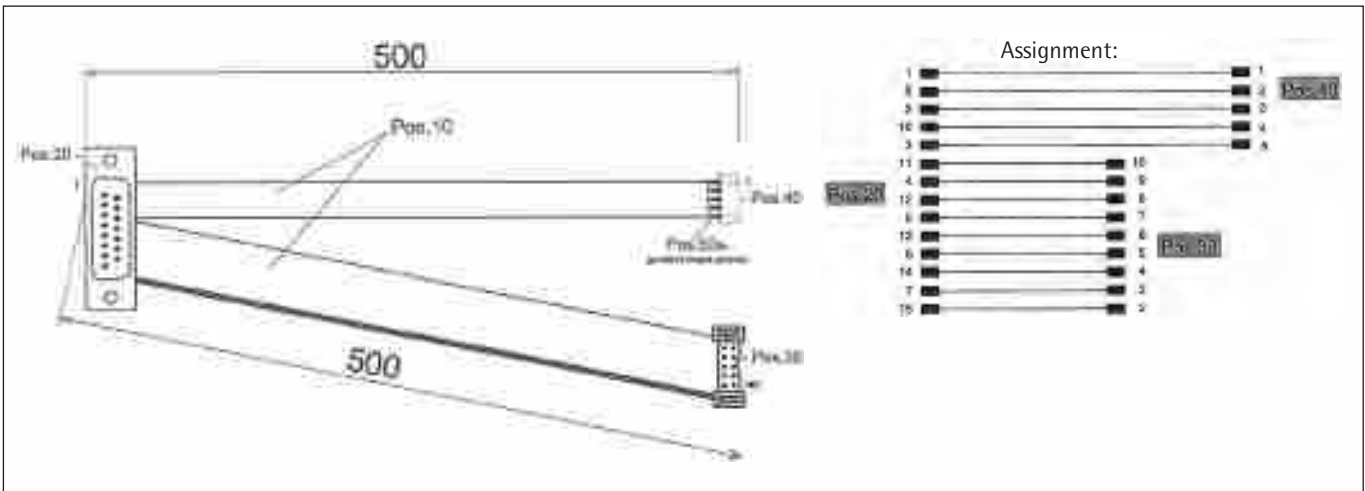

Pos.:	Name:	Manufacturer:	Manufacturer#:	Internal article #:	Cut length:	Quantity:	Approvals/Notes:
10	Cable ribbon, AWG28 15-pin gray	3M	3365	57001-318-01	500 mm	1x	UL file no. E42769
20	Male connector, D-SUB 15-pin IDC			54101-020-01		1x	
30	Male connector, 10-pin IDC	3M	4610-6051	010800		1x	UL file no. E68080
40	Pin strip, 5-pin solder	JST	B5B-XH-A	57002-151-01		1x	or 57001-883-01 UL recognized E60389
50	Shrink tubing 2.4 x 12			31335-202-02		5x	

 The user can create this cable himself/herself. The ambient conditions must be non-critical.

Error Messages

Error codes are displayed for about 2 seconds. The program then returns automatically to the weighing mode.

Display	Cause	Solution
HIGH or ERR 55	Weighing capacity exceeded	Unload the weighing pan
LOW or ERR 54	Contact between load plate and environment, load on weighing pan too light	Move the object that is touching the weighing pan
APP.ERR.	Cannot store data: Load on weighing pan too light or no sample on pan while application is active	Increase load
DIS.ERR.	Data output not compatible with output format	Change the configuration with output format in the operating menu
PRT.ERR.	Data interface for printer output blocked	Reset the menu factory settings or Contact your local Sartorius Service Center
ERR 02	Calibration parameter not met, e.g.: – Unstable – Tare – Load on weighing pan	Correct the setup conditions Calibrate only when zero is displayed Unload the balance/scale
ERR 10	“Tare” function is locked for active application program “Net total”; Only 1 tare function can be used at a time	Clear the tare memory to unlock the “Tare” function
ERR 11	Tare memory not allowed:	Carry out “Tare” function
ERR 03	Zero point error at the end of calibration	Check installation conditions, note warm-up time Repeat calibration
ERR 06	Int. calibration weight faulty or not available	Service
ERR 08 <> Zero range	Error during zeroing (value outside 2%)	Repeat process
ERR 09 < 0 not allowed	Error during taring (tare value ≤0)	Repeat process
ERR 19 Preload is too high	The preload to be applied is too high	Change the preload value
ERR 30	The balance/scale is in BPI mode	With service tool – carry out “close” function
ERR 50 or 53	TC converter failure	Service
ERR 241	Checksum error	Service
ERR 243	Checksum error	Carry out menu reset
ERR 245 or 247	Checksum error	Calibration/Adjust the balance/scale
ERR 249	Checksum error	Service
The weight readout changes constantly	Unstable ambient conditions (excessive vibration or draft) Foreign object is caught between weighing pan and balance/scale housing	Setup location unstable Adjust Setup configuration Remove the foreign object
The weight readout is obviously wrong	The balance/scale was not calibrated/adjusted Balance/scale was not tared before weighing	Adjustment Tare

If any other errors occur, contact your local Sartorius Service Center.
For contact information go to: <http://www.sartorius.com>

Overview

Specifications

Model	Standard specifications					Customer-specific modifications
	WZA224-LC	WZA224-L	WZA54-L	WZA523-L	WZA8202-L	
Technology	EMFR	EMFR	EMK	EMFR	EMFR	
Weighing Capacity	g	220	220	50	520	6200
Readability	g	0.0001	0.0001	0.0001	0.001	0.01
Required preload on the load receptor	g	10	10	5	30	350
Tare range (subtractive)	g	over entire weighing range				
Repeatability (standard deviation) ¹⁾	<±g	0.0001	0.0001	0.0002	0.001	0.01
Linearity	<±g	0.0002	0.0002	0.0005	0.002	0.02
Measurement time ³⁾	s	0.6	0.6	0.8	0.6	0.6
Adaptation to ambient conditions		By selection of 1 of 4 optimized filter levels				
Operating temperature range	°C	+10...+30 °C				
Allowable ambient operating temperature	°C	+5...+40 °C				
Sensitivity drift within +10... +30 °C	<±/K	1 · 10 ⁻⁶	1 · 10 ⁻⁶	1 · 10 ⁻⁶	2 · 10 ⁻⁶	2 · 10 ⁻⁶
External calibration weight (min accuracy class)	g	50 (E2)	50 (E2)	10 (E2)	200 (F1)	2000 (F1)
Net weight, approx.	kg	2.2	1.15	0.62	1.15	1.15
Power supply	VDC	min. 12 ... 26 max., optimal 15 V (+15% to -10%)				
Ripple 50/60 Hz	VDC	0.5 Vpp (voltage peak-to-peak)				
Power consumption		3.4 W average				
Switch-on current		6 W average (weigh cell only)				
Built-in interface		RS-232C-S/V24-V28; 7-bit; even, mark, odd, space; Transmission rates: 150 to 19200 baud, 1 or 2 stop bits; software/hardware handshake				

¹⁾ = Depends on system design

²⁾ = For operation with greater preload setting, please send e-mail to request PC configuration software; e-mail address: fast.factory@sartorius.com
Greater preloads are possible, but reduce the weighing capacity.

³⁾ = The weighing time is the time period in which the measured value oscillates within a range of ±3x the standard range of the static end value.
Test weight approx. 25% of max.

Dimensions (Scale Drawings)

Weigh Cell Model:
WZA224-LC

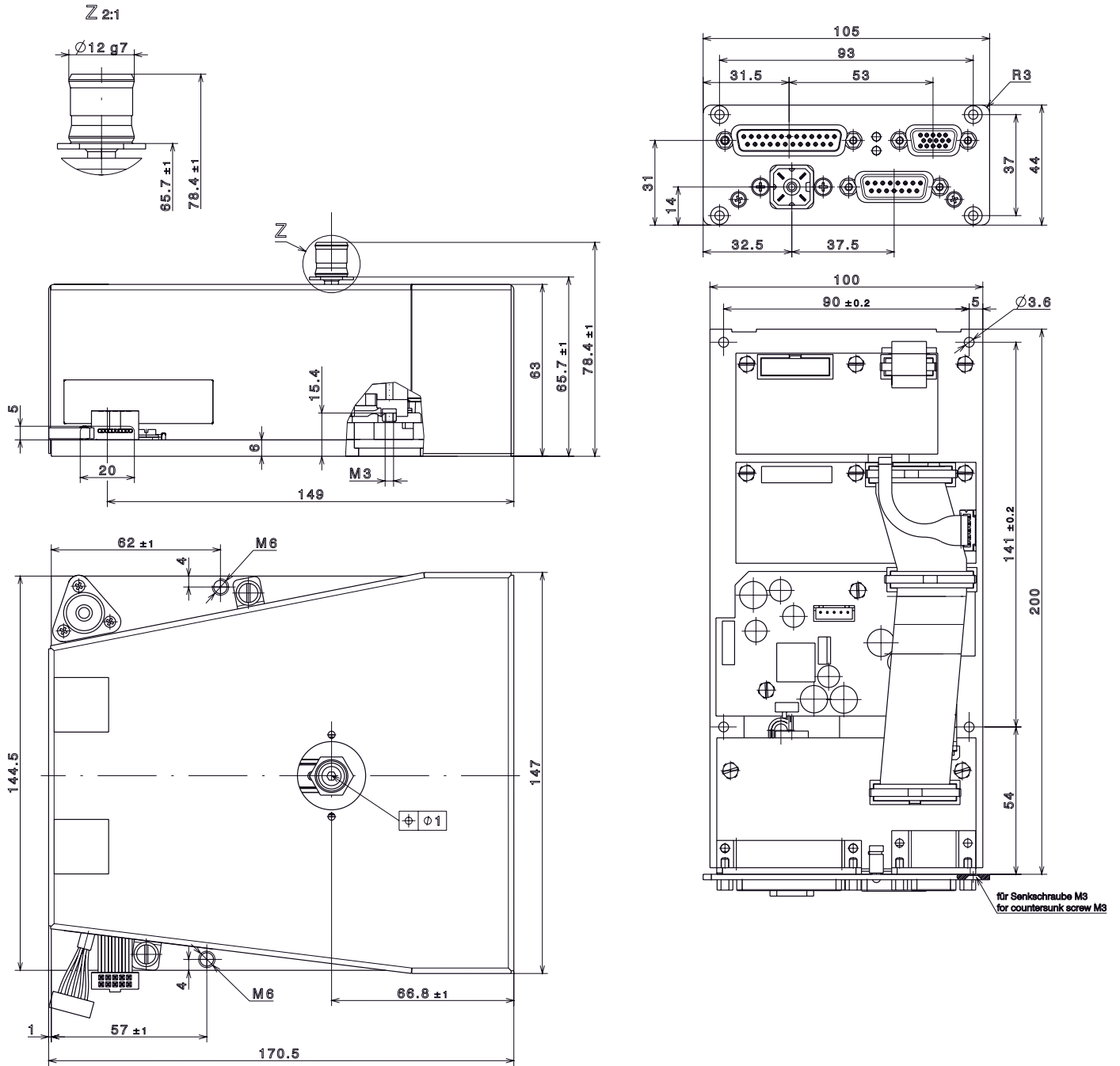

All dimensions are given in millimeters

Dimensions (Scale Drawings)

Weigh Cell Model:
WZA224-L

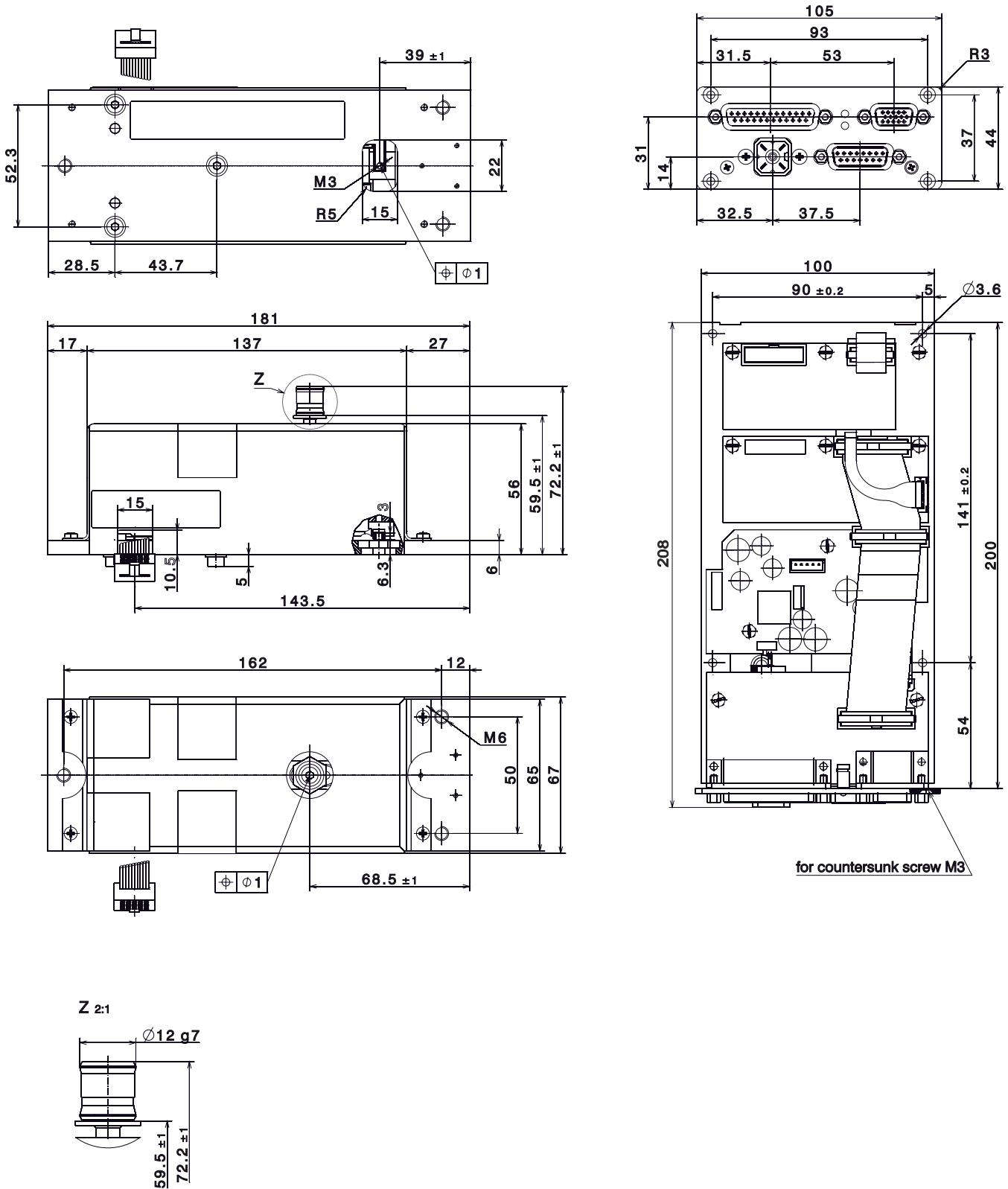

All dimensions are given in millimeters

Dimensions (Scale Drawings)

Weigh Cell Model:
WZA54-L

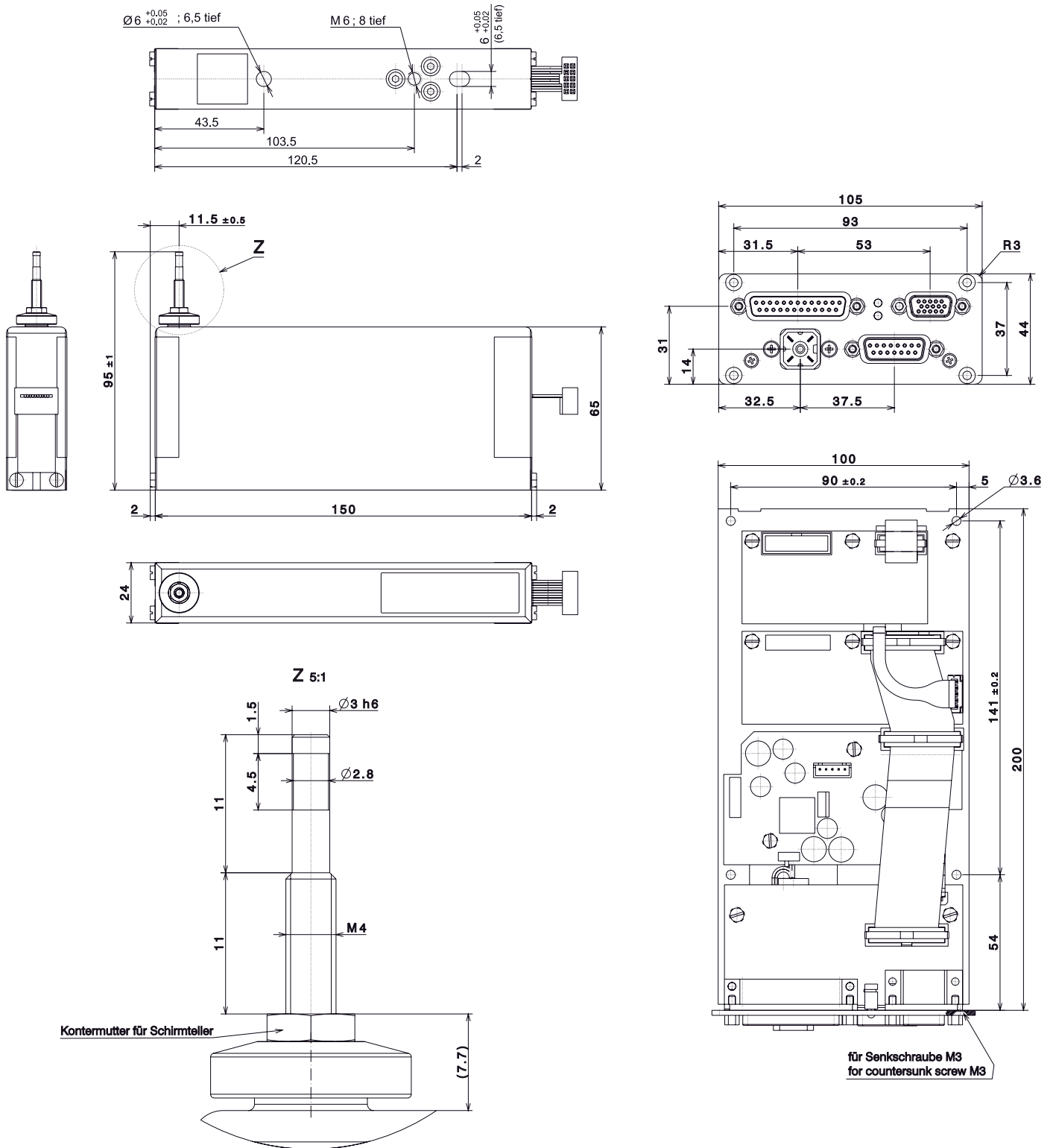

All dimensions are given in millimeters

Dimensions (Scale Drawings)

Weigh Cell Model:
WZA523-L

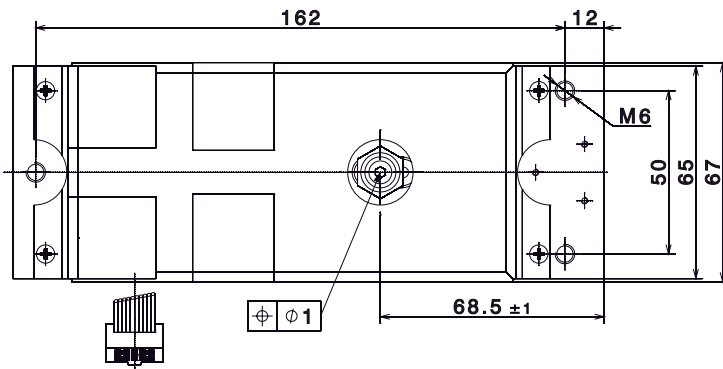
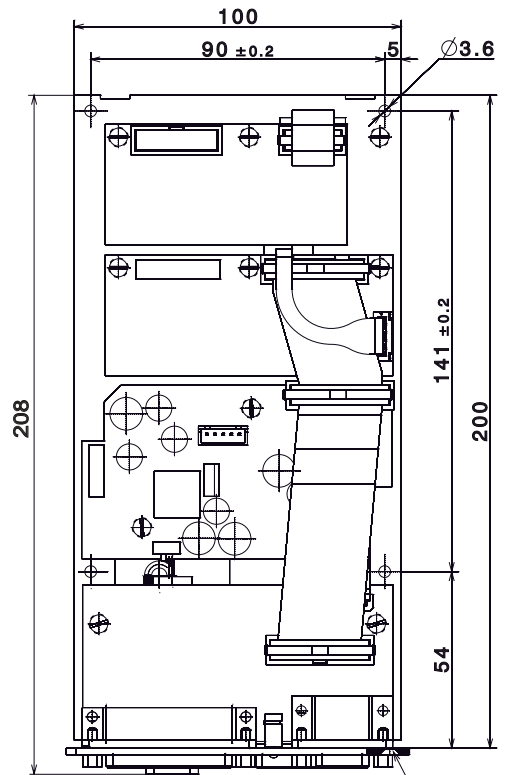
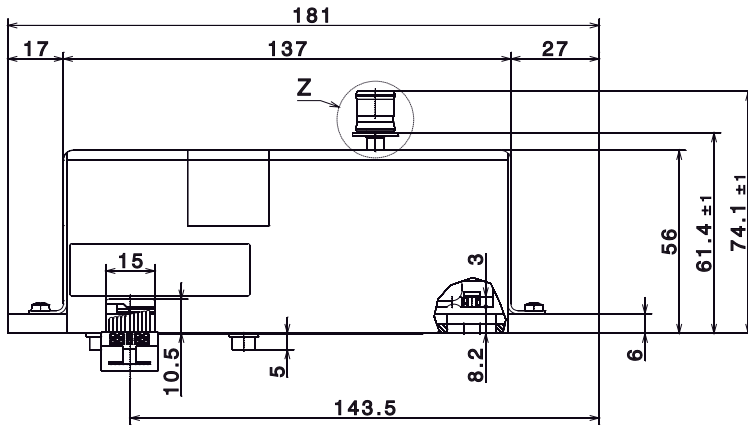
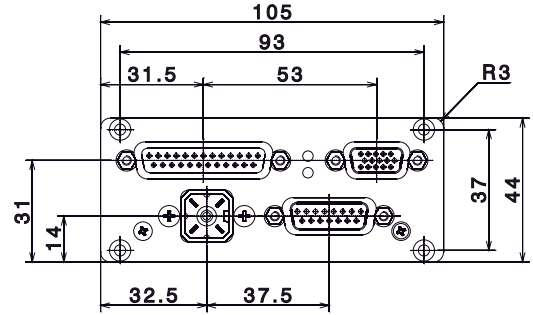
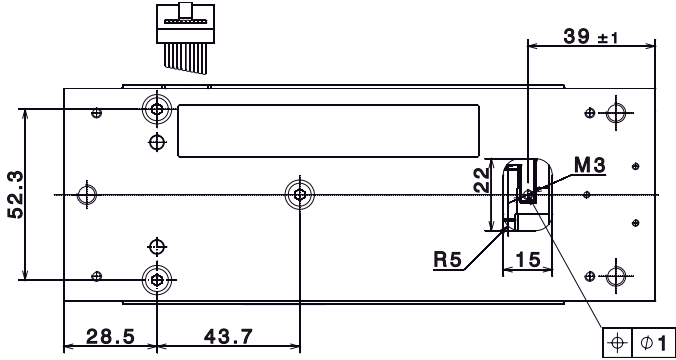

for countersunk screw M3

Z 2:1

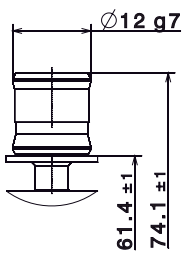

All dimensions are given in millimeters

Dimensions (Scale Drawings)

Weigh Cell Models:
WZA8202-L

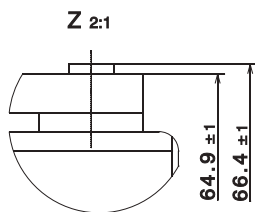
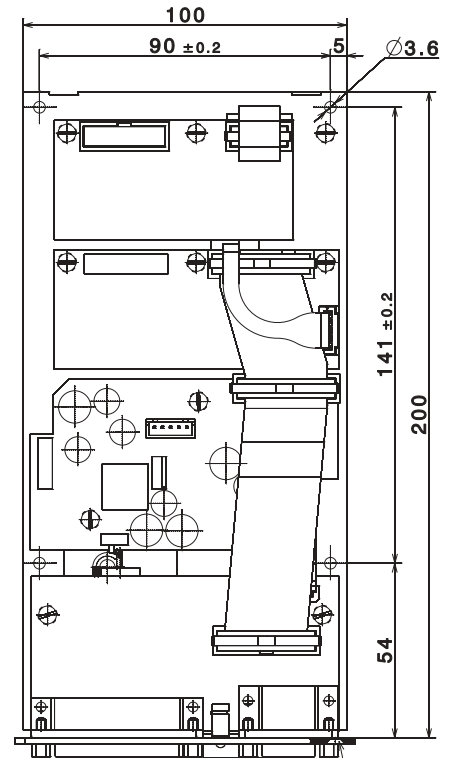
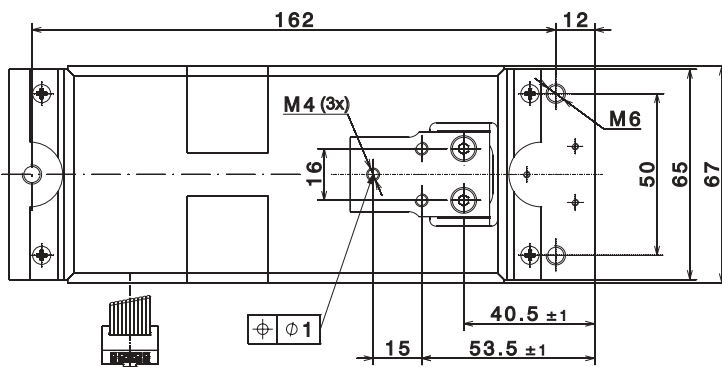
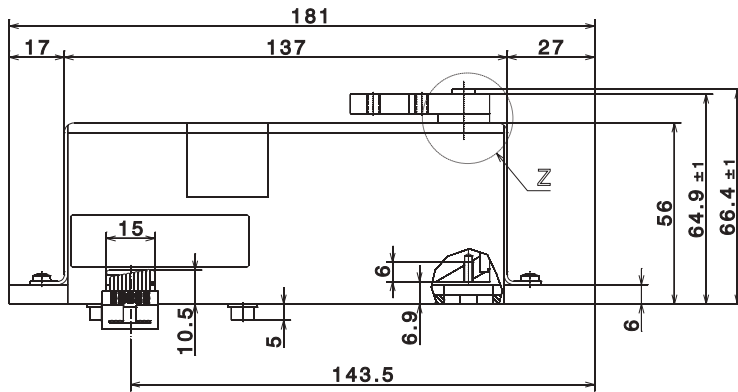
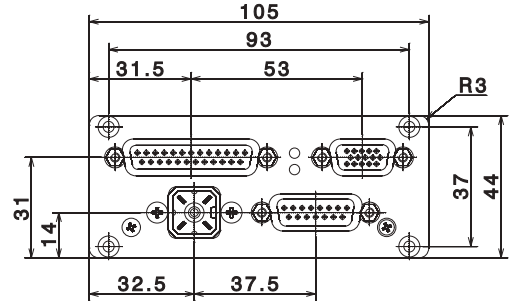
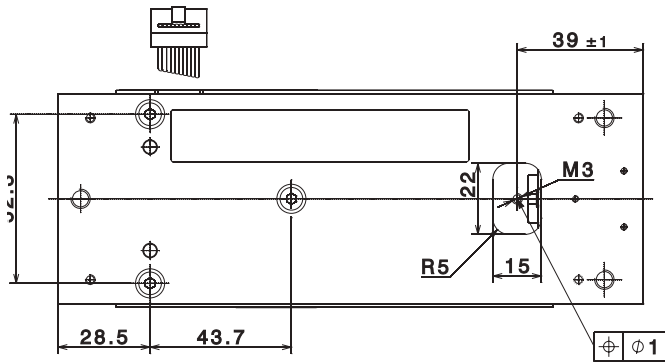

All dimensions are given in millimeters

Accessories

Product	Order No.
Display and control unit with cable (0.9 m) for connection to enclosed electronics module	YAC01ED
Configuration software for settings, calibration/adjustment and setting the preload	Cubis CAS Suite
SartoConnect data transfer software (for loading weight values in a PC running Windows® 95/98/NT and direct processing with application programs such as Excel, Access, etc.) incl. adapter cable (1.5 m) from weigh cell to PC (12-pin to 9-pin)	YSC011
Data cables RS-232	
- for PC connection, 25-pin	7357312
- for PC connection, 9-pin	7357314
AC adapter	
IP40 protection in accordance with VDE* 0470/529	
- Europe	6971886 or 6971984 + 6971953
- USA, Canada, Japan	6971984 + 6971954
- GB	6971984 + 6971955
- Australia, New Zealand	6971984 + 6971956
- South Africa	6971984 + 6971957
- India	6971984 + 6971964

Additional options and accessories available on request

* VDE = Verband der Elektrotechnik, Elektronik, Informationstechnik (Association for Electrical, Electronic & Information Technologies)



sartorius



Konformitätserklärung *Declaration of Conformity*

Sartorius Weighing Technology GmbH
Wendler Landstr. 94 - 108
37075 Göttingen, Germany

erklärt in alleiniger Verantwortung, dass das Betriebsmittel
declares under own responsibility that the equipment

Geräteart: **Wägesinheit in Komponenten-Bauweise**
Device type: Weighing unit Component design

Baumreihe / Type series: **WZA...L + YAC01ED**

übereinstimmt mit den Regelungen der Europäischen Richtlinie (in der heute gültigen Fassung):
complies with the regulations of the European Directive (in the today valid version):

Richtlinie 2002/95/EG: **Zur Beschränkung der Verwendung bestimmter gefährlicher Stoffe
in Elektro- und Elektronikgeräten**

*Directive 2002/95/EC: on the restriction of the use of certain hazardous substances in electrical
and electronic equipment*

sofern das Betriebsmittel gekennzeichnet ist mit:
provided that the equipment is marked with:



Sartorius Weighing Technology GmbH
Göttingen, 2012-10-14

Dr. Reinhard Baumfalk
Vize Präsident R&D

Dr. Dieter Klaußner
Head of International Certification Management

Diese Erklärung bescheinigt die Übereinstimmung mit den genannten EU-Richtlinien, ist jedoch keine Zusicherung
von Eigenschaften. Sollten sich nach abgeschlossener Änderung des Protokolls weitere diese Erklärung ihre
Gültigkeit. Die Sicherheitsanforderungen der zugehörigen Produktionskennzeichnung sind zu beachten.

*This declaration certifies conformity with the above mentioned EC Directives, but does not guarantee product
attributes. Unauthorised product modifications make this declaration invalid. The safety instructions in the
associated product documentation must be observed.*

Formular: Rücklieferung
Form: Return delivery



sartorius

Page 1 of 1

Bitte dieses Formular dem Gerät beilegen
Please attach this form to the instrument
being returned

Rücklieferungsnummer / Meldungsnummer Goods return number / Registration number

Zu beachten!

Um eine Gefährdung unserer Mitarbeiter durch Kontaminationen ausschließen zu können, ist eine Bearbeitung nur mit ausgefüllter Dekontaminationserklärung möglich.

Important Note!

To protect our employees from health hazards due to contamination, we will only accept return products if we have a completely filled Declaration of about Decontamination.

An To:		Von From:	
Sartorius Weighing Technology GmbH			
Servicezentrum Mechatronik / Geb. 15			
Weender Landstraße 94-108			
37070 Göttingen			
Germany			
Typ Model	Serien-Nr. Serial no.	Kunden-Nr. Customer no.	
Zubehör Accessories	Bestell-Nr. / Rechnungs-Nr. Order no. / Invoice no		

Informationen zur Rücksendung Informations on return delivery	
<input type="checkbox"/> Produkt defekt Product defective: <input type="checkbox"/> Lieferung unvollständig Delivery incomplete: <input type="checkbox"/> Falschlieferrung Wrong delivery: <input type="checkbox"/> Konsignationsgerät Goods on consignment: <input type="checkbox"/> Anderer Grund Other reason:	
<input type="checkbox"/> Nach Reparatur ins Fertiglager Return to stock after repair <input type="checkbox"/> Nach Reparatur zurück an Absender Return to sender after repair <input type="checkbox"/> Kostenvoranschlag an Quotation to: <input type="checkbox"/> Weiterleiten an Forward to: <input type="checkbox"/> Information an Information to: <input type="checkbox"/> Sonstiges / Bemerkungen Other / Remarks:	<input type="checkbox"/> Nach Reparatur ins 2.Wahl-Lager Return to second hand stock after repair <input type="checkbox"/> Entsorgen Scrap

 Kontaktperson | Contact person Tel.-Nr. | Phone no. Fax-Nr. | Fax no. Kostenstelle | Cost Center

 Datum | Unterschrift (Kontaktperson)
 Date | Signature (Contact person)

 Genehmigt | Datum | Unterschrift
 Approved | Date | Signature

Declaration about decontamination



Declaration about decontamination and cleaning of equipment and components

To protect our personnel, we require all equipment or components be free of biological, chemical, or radio active contaminants. We will only accept such equipment or components when:

- the equipment or components have been adequately CLEANED and DECONTAMINATED.
- this declaring document has been completed, signed and returned by an authorized person.

Please help us in assuring a safe, hazard-free work environment.

Description of the Equipment or Component(s)

Description / Cat. No.:	
Serial no.:	
No. of invoice/delivery note	
Date of delivery:	

Contamination / Cleaning

Attention: Please specify exactly the biological, chemical, or radioisotopic contaminant.	Attention: Please describe the cleaning and decontamination procedure/method.
The equipment was contaminated with:	and it has been cleaned and decontaminated by

Legally binding declaration

I (we) certify that all information given in this form is correct and complete.
The equipment and components have been adequately decontaminated and cleaned according to the legal requirements. No chemical or biological or radio active risks remain that can endanger exposed persons' safety or health.

Company / Institute:			
Address / Country:			
Tel.:		Fax (with area code):	
Name of the authorized person:			
Position:			
Signature / Date:			

Please pack the equipment properly and send it to your local service representative or to Sartorius Weighing Technology GmbH, Germany.

Sartorius Weighing Technology GmbH Servicezentrum Mechatronik Weender Landstraße 94-108 37070 Göttingen Deutschland

Sartorius Weighing Technology GmbH
Weender Landstrasse 94-108
37075 Goettingen, Germany

Phone +49.551.308.0
Fax +49.551.308.3289
www.sartorius.com

Copyright by
Sartorius Weighing Technology GmbH,
Goettingen, Germany.

No part of this publication may be
reprinted or translated in any form or
by any means without prior written
permission from Sartorius.

All rights reserved by Sartorius in
accordance with copyright law.

The information and figures contained
in these instructions correspond to the
version date specified below. Sartorius
reserves the right to make changes to
the technology, features, specifications
and design of the equipment without
notice.

Date:
March 2014,
Sartorius Weighing Technology GmbH,
Goettingen, Germany