

The WZA-NC series



OEM weigh cells

WZA224-NC
 WZA523-NC
 WZA1203-NC

Outstanding features:

The WZA-NC series is the successor of the well established WZA...CW-line. This weigh cells are specialized on weigh resolutions as low as 0.1 mg and capacities of up to 8200 g. An internal calibration weight for easy quality control during production is built in.

The weigh cell consist of two parts:

- A monolithic weighing system in stainless steel IP44 housing
- Aluminium electronic box, all connection via the front
- Force compensation technology weighing system with a resolution of 0.1 mg
- Internal calibration weight for easy checks in automated environments
- Excellent weighing technology bundled with easy adaptation
- Adjustable load receptor with overload protection, optional lift-off protection
- Possibility for under floor weighing
- Interconnection on electronic front panel
- LED's to control power and data transfer
- Fast warm-up by separation of weighing system and electronics
- RS232C interface for configuration and data transfer
- Optional PC-software with menu setting, weigh data display and internal calibration functions
- Display can be plugged during operation

Model WZA...	224-NC	523-NC	1203-NC
Capacity	220 g	520 g	1200 g
Readability	0.1 mg	1 mg	1 mg



WZA...-NC

Dimensions in mm

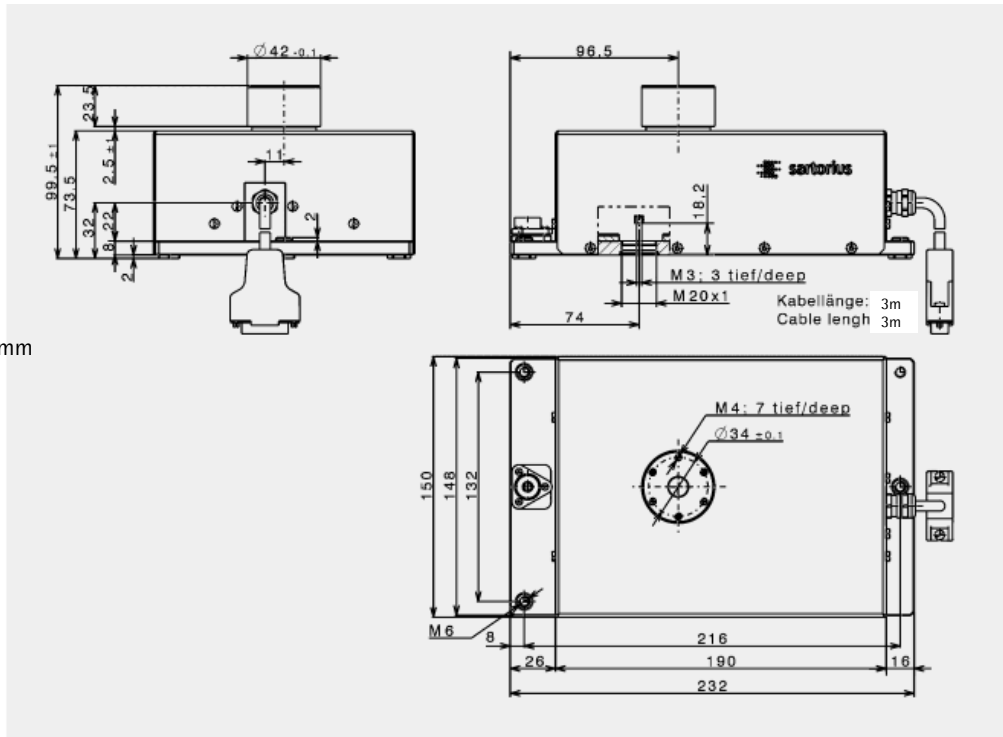

Technical Data

Model	WZA224-NC	WZA523-NC	WZA1203-NC
Capacity	220 g	520 g	1200 g
Readability	0.1 mg	1 mg	1 mg
Preload max. ¹⁾	70 g	50 g	0 g
Repeatability (standard deviation) ²⁾	≤± 0.1 mg	≤± 1 mg	≤± 1 mg
Linearity	≤± 0.2 mg	≤± 2 mg	≤± 2 mg
Measuring time ^{2) 3)}	0.6 s / ± 0.1 mg	0.6 s / ± 1 mg	0.6 s / ± 1 mg
Operating temperature range	+10 +30 °C		
Allowable temperature range	+5 +40 °C		
Weigh cell dimension	150 x 232 x 99 mm (base x height)		
Electronic / PCB dimension	130 x 208 x 45 mm (base x height)		
Load receptor (adjustable, with overload protection)	42 mm (diameter), 26 mm height above housing		
Under floor load receptor	M3 thread		
Cable length weigh cell to electronics	3 m		
Power supply	TNG11-2 UNI / 6971993, 115/230 V _{AC} , +15 ... - 20%, 48-60 Hz		
Power supply (alternative)	12...26, optimal 15V (+15% -10%); 0.5V _{PP} (Peak to Peak)		
Power consumption	8 VA (average)		
Interface	RS232C , software / hardware handshake; No system power via RS232 connector		

Options / Accessories

Windows configuration software for test and adjustment	Sartorius CAS Suite
Liquid-crystal display	YAC01ED
Weigh pan to realize lift off protection	YWP01WZA

Sartorius Weighing Technology GmbH
Weender Landstrasse 94-108
37075 Goettingen, Germany

Phone +49.551.308.0
Fax : +49.551.308.3502

info.mechatronics@sartorius.com
www.sartorius-mechatronics.com

- 1) the preload can be configured by using the Sartorius CAS Suite software; higher preload will reduce the weighing range
- 2) depending on measurement equipment set-up and conditions;
- 3) measuring time is the time in which the measured value is in the given range around the static end value; test weight is approx. 25% of the weighing range.

Specifications are subject to change without notice.

Current status: July 2011
Version: 2.0