



Streamlined Purification of Plasmid DNA From Prokaryotic Cultures

Introduction

Plasmid DNA has become an essential element of molecular biology and protein research. This invaluable tool is at the root of molecular biology research and required for expression of recombinant proteins in a variety of host organisms. Various applications require different amounts of plasmid DNA, but typically the purification process starts with small cultures. Advances in cloning techniques have greatly increased the number of samples requiring small-scale plasmid preparation, or minipreps. The large-scale purification schemes of the past have given way to the development of small-scale, massively parallel purifications requiring semi-automated or fully-automated handling.

A number of manufacturers sell complete kits for plasmid preparation from small-scale to large-scale. Minipreps are available in single spin tubes, as well as 96-well formats. Providing a complete kit solution allows sellers to increase costs for end users. Pall has created a cost effective alternative for efficient parallel clarification and plasmid DNA purification from *E. coli* cultures. The process starts with an optimized lysate clarification filter plate followed by purification on a high binding capacity DNA binding filter plate.

Purification of plasmid DNA requires the clarification of the sample once the cells are lysed and the lysate has been treated with salts to precipitate the detergent. This step is necessary to remove the cellular debris. Centrifugation is the primary method used to separate cellular debris when processing in single tube format. Many issues arise when

purifying plasmid DNA in high throughput format using centrifugation to sediment the cellular debris. First, it is very difficult to pellet the cellular debris, typically a fluffy pellet, in a multi-well plate and recover the supernatant. Other problems with centrifugation of cellular debris include long spin times, rotor capacity for single tube processing, and handling issues associated with using microfuge tubes. Perhaps the greatest problem is that sedimentation allows the fluffy pellets to trap a large portion of the desired plasmid DNA.

Silica-based media and glass fiber membrane have become the standard for DNA binding in the plasmid preparation process. Chaotropic salts facilitate binding of DNA to the media. This creates a convenient way to wash away contaminants prior to eluting the DNA with a neutral solution, such as TE Buffer or water. Filter plates containing silica-based media can easily be processed by vacuum filtration or centrifuge to yield desired quantities of plasmid DNA.

Vacuum filtration, which is easily automated, is relatively quick and allows the use of an additional wash step to maximize sample recovery. Filtration can be done effectively in either a vacuum or centrifugal mode, ultimately maximizing the choice in protocols available to the researcher. In this Application Note, we compare vacuum filtration to centrifugation for DNA purification. In addition, we demonstrate the benefit of using a filter plate configuration with an integral prefilter for lysate clarification. Prefiltration allows efficient lysate clearance and collection of the clarified lysate directly into a DNA binding plate.

The following protocol represents a complete process for 96 plasmid preparations starting from prokaryotic culture and ending with high purity DNA. Multi-well filtration for lysate clearance and DNA purification creates a streamlined process for plasmid preparation. The streamlined method can be processed either manually, semi-automated or fully-automated.

Materials and Methods

- AcroPrep™ Advance filter plate, 1 mL, 3 µm glass fiber/ 0.2 µm Supor® membrane for clarification (PN 8175). Alternatively the 350 µL plate (PN 8075) can be used.
- AcroPrep Advance filter plate, 1 mL, for DNA Binding (PN 8132)
- 2 mL deep well culture plates
- Collection plates
- UV/Vis clear plates for sample analysis
- Vacuum manifold (PN 5017)
- Vacuum/pressure pump (PN 13157) or centrifuge with plate holders
- Plate shaker

Table 1

Buffer	Composition
Resuspension Buffer	50 mM Tris-HCl, pH 8.0, 10 mM EDTA, 100 µg/mL RNase A
Lysis Buffer	200 mM NaOH, 1% SDS
Neutralization Buffer	3.0 M Potassium Acetate, pH 5.5
Binding Buffer	6 M Guanidine-HCl
Washer Buffer	80% Ethanol
Elution Buffer	10 mM Tris-HCl, pH 8.0, 1 mM EDTA or DNase, RNase free water

Lysate Clearance and DNA Binding Protocol

1. Grow *E. coli* cultures transformed with desired plasmid DNA in deep well plates (1 mL of culture/well) in Luria Broth with appropriate antibiotic overnight at 37 °C with shaking.
2. Pellet *E. coli* in culture plate at 5,000 x g for 10 minutes, then decant supernatant.
3. Resuspend each pellet in 100 µL Resuspension Buffer.
4. Add 100 µL/well Lysis Buffer and shake using plate shaker for 2 minutes.
5. Add 100 µL/well Neutralization Buffer and shake for 2 minutes.
6. Transfer cell lysate to lysate clarification plate (PN 8175).
7. Place DNA binding plate on top of 350 µL collection plate and place into bottom of vacuum manifold. Assemble vacuum manifold (see Figure 1).
8. Place lysate clarification plate on top of vacuum apparatus.
9. Apply vacuum at 10 in. Hg (0.34 bar) and collect filtrate into DNA binding plate. **Do not use vacuum greater than 12 in. Hg. (0.41 bar).**
10. Disassemble vacuum manifold. Place 2 mL waste collection plate in bottom of apparatus and move the DNA binding plate to the top of the manifold (see Figure 2).

Figure 1
Instructions for Set Up of Vacuum Manifold for Lysate Clarification

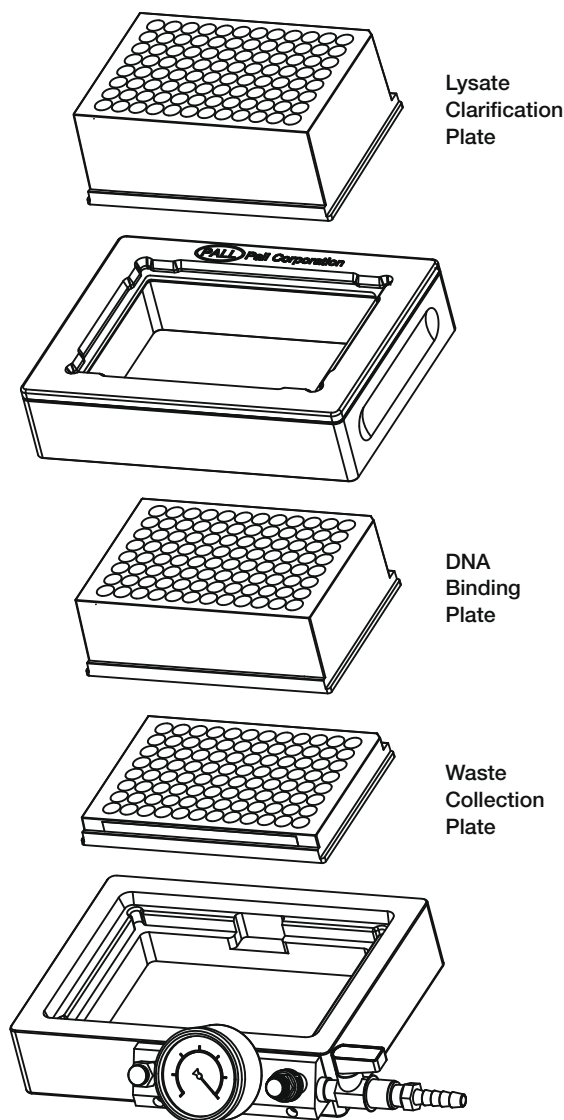
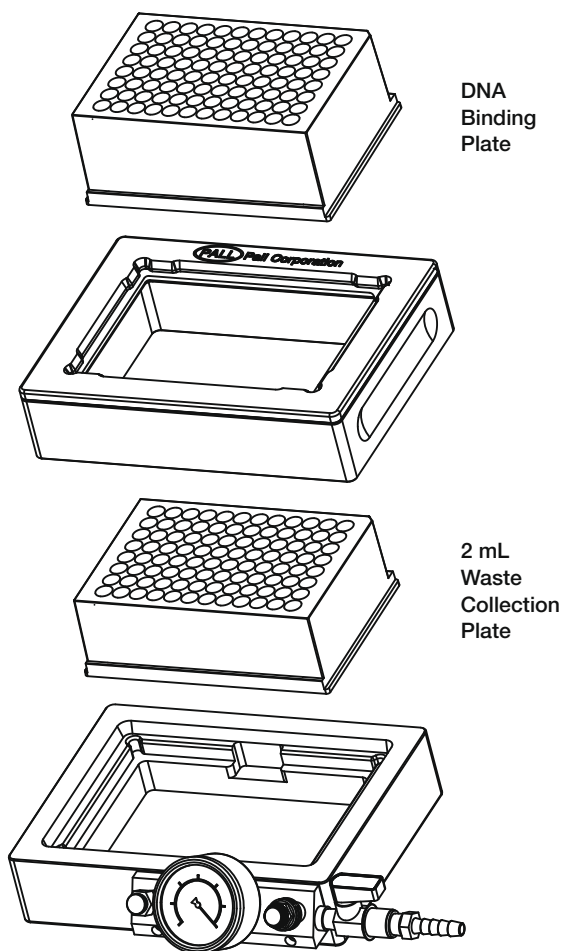

Figure 2

Instructions for Set Up of Vacuum Manifold for DNA Binding



11. Add 300 μ L/well Binding Buffer and pipette up and down to mix.
12. Apply vacuum [\sim 5 in. Hg (0.17 bar)] for slow vacuum] and discard filtrate. DNA is now bound to membrane.
13. Wash with 400 μ L/well of Wash Buffer.
14. Apply vacuum, then discard the filtrate. Discard unnecessary if using 2 mL collection plate or filtering directly to waste.
15. Repeat steps 13 and 14.
16. Blot bottom of filter plate on absorbent towel to dry.
17. Apply vacuum once more for 5-10 minutes to ensure removal of residual alcohol.
18. Blot bottom to ensure removal of ethanol droplets.
19. Add 70 μ L/well Elution Buffer. If higher DNA concentration is desired, volume can be reduced to 50 μ L/well, but the average total yield will be lower.
20. Incubate the plate at room temperature for one minute.

21. Purified DNA can be eluted by either vacuum or centrifugation.

- a. By vacuum – place clean collection plate (DNase, RNase free) into vacuum manifold. Place filter plate on top of vacuum manifold, apply vacuum at 15 in. Hg (0.5 bar) for 1 minute until all elution buffer has passed through the DNA binding plate. Collect purified DNA (see Figure 3).
- b. By centrifugation – place purification filter plate on top of clean collection plate and centrifuge at 1,000 x g for 5 minutes.

Figure 3

Instructions for Set Up of Vacuum Manifold for Vacuum Elution

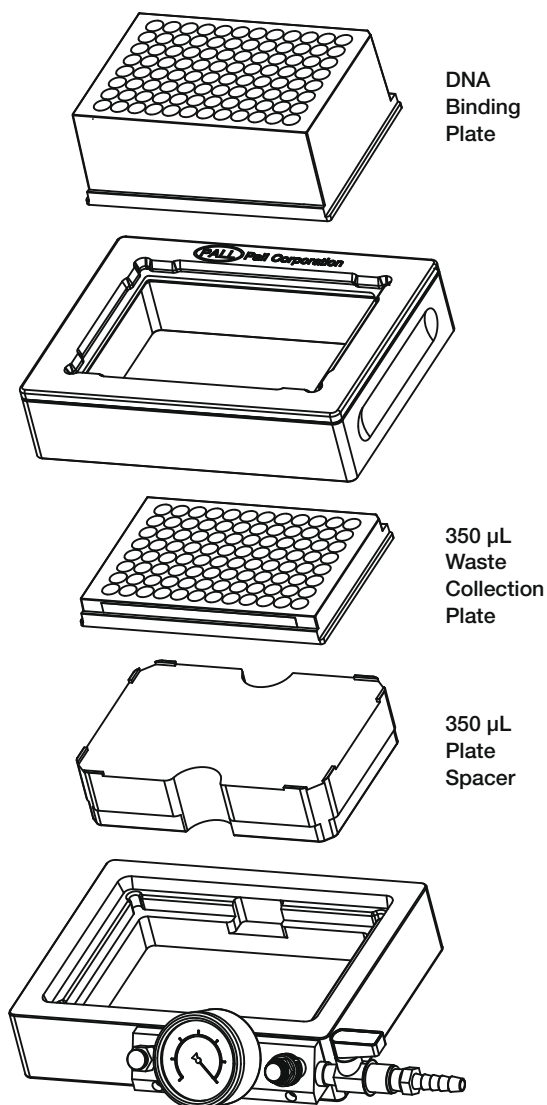

22. Measure OD_{260/280}, calculate concentration of purified DNA.
23. Perform agarose gel analysis of the purified pDNA.

Results

E. coli lysate was clarified using traditional centrifugation and Pall AcroPrep Advance lysate clarification filter plates. Figure 4 shows similar reduction of debris (OD₃₂₀) for both methods as compared to starting material.

Plasmid DNA at three concentrations was spiked into TE buffer and passed through the AcroPrep Advance lysate clarification filter plate (3 µm glass fiber/0.2 µm Supor membrane, PN 8075). A comparison of plasmid DNA concentration, pre- and post-filtration, shows ~100% recovery (Figure 5) at all three concentrations.

Figure 4
Filtration Simplifies Clarification

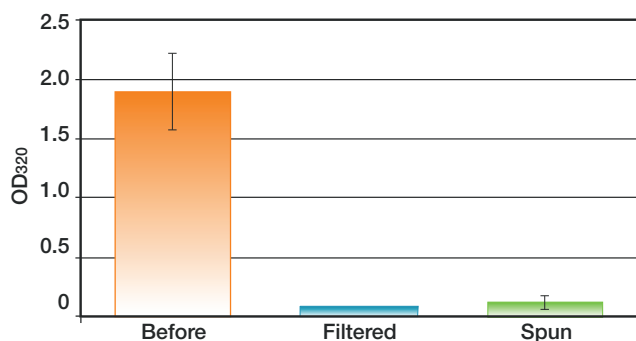

Triplicate samples of 300 µL of crude lysate clarified by vacuum filtration (350 µL AcroPrep Advance lysate clarification filter plate) or traditional centrifugation. OD₃₂₀ measured before and after clarification.

Figure 5
Full Recovery of pDNA After Passage Through AcroPrep Advance Lysate Clarification Filter Plate

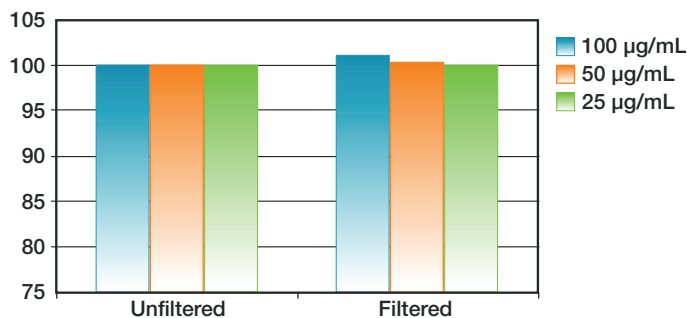

300 µL TE buffer spiked with pCAT at 25, 50 and 100 µg/mL. DNA concentration and recovery calculated from OD₂₆₀ before and after filtration, N = 2.

To demonstrate the recovery of DNA from clarified *E. coli* lysate, plasmid DNA was spiked into crude lysate and then clarified by filtration. The same plasmid DNA was added to cell lysate following filtration. Electrophoresis was performed on aliquots from each sample (Figure 6). A single, clear band of similar intensity from each sample demonstrates little if any DNA loss during the filtration-based clarification step.

Figure 6
Good Recovery of pCAT DNA After Clarification

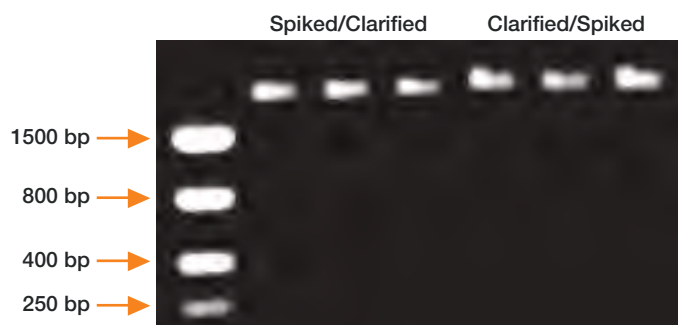

Equal amounts of pUC19 spiked into lysate before or after clarification, then diluted 1 to 10 in TE buffer. Loaded 2 µL/lane on 1.2% Agarose gel.

Figure 7
Higher Plasmid DNA Yield Per Well With Pall AcroPrep Advance DNA Binding Filter Plate Than Competitor Plates

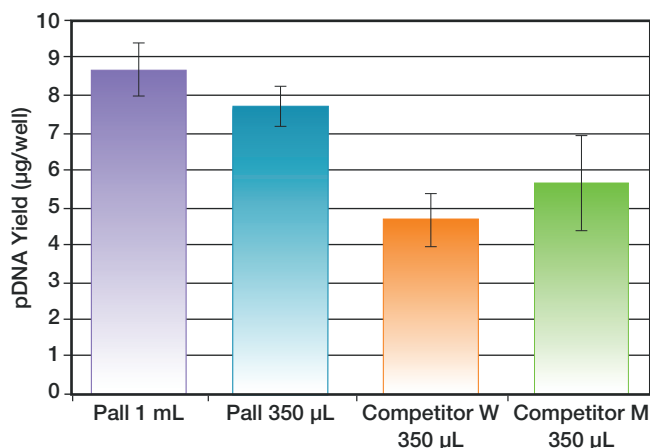

pCAT plasmid DNA yield (OD₂₆₀) using indicated DNA purification plates with 1 mL (Pall and Competitor M) or 1.5 mL (Competitor W) overnight culture of DH5α. Purification using plate manufacturer's recommended protocol. Error bars indicate standard error (n ≥ 6).

Cultures of *E. coli* containing pCAT plasmid DNA were purified from *E. coli* lysates using Pall's 350 µL and 1 mL DNA binding filter plates, as well as two competitive 350 µL DNA binding plates. All purifications were performed as specified in the manufacturer's recommended protocol. The highest DNA concentration and total yield are seen from Pall's 1 mL AcroPrep Advance DNA purification filter plate (Figure 7 and Table 2). Although Competitor W also shows high DNA concentration (155 ng/µL), total DNA yield is the lowest (4.7 µg/well) due to the low recovery volume, ~30 µL. Competitor M gave the lowest concentration of DNA at 108 ng/µL with a total yield of 5.6 µg/well.

Table 2*Plasmid DNA Yield From Various Filter Plates*

	AcroPrep Advance Filter Plate, 1 mL	AcroPrep Advance Filter Plate, 350 μ L	Competitor W Filter Plate, 350 μ L	Competitor M Filter Plate, 350 μ L
Elution Volume	70 μ L	70 μ L	50 μ L	70 μ L
Recovered Volume	52 μ L	60 μ L	30 μ L	52 μ L
OD _{260/280}	1.97 \pm 0.013	1.95 \pm 0.014	1.98 \pm 0.013	2.04 \pm 0.05
Concentration (ng/ μ L)	167.1	131.5	155.2	108.4
Total Yield (μ g/well)	8.7	7.7	4.7	5.6

OD_{260/280} was measured by using pooled purified pDNA ($n \geq 6$).

OD_{260/280} as indicator of purity expected between 1.7-2.0.

Agarose gel analysis of purified pCAT DNA from the three different DNA binding plates is shown in Figure 8. Each collected sample volume was adjusted to 65 μ L to correct for differences in recovery volume prior to electrophoresis. All samples show supercoiled plasmid DNA, but DNA yield from each of the filter plates varies.

Figure 8

Agarose Gel Analysis of pCAT DNA Purified on Indicated DNA Binding Plate

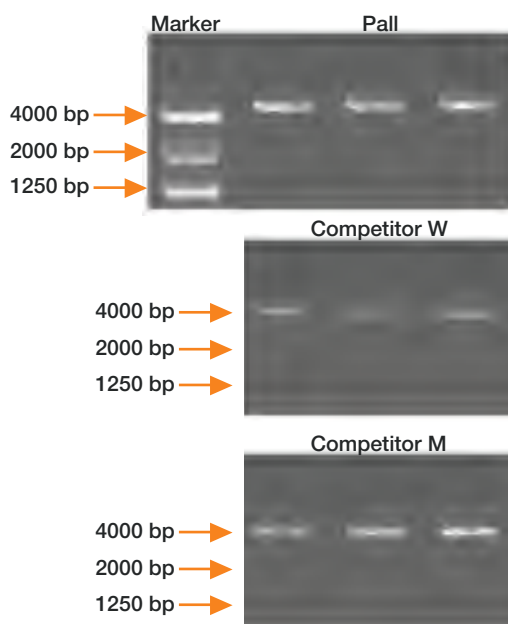

1.2% Agarose gel electrophoresis of the purified pDNA. Pooled samples from three separate purifications, eluate adjusted to 65 μ L after purification, diluted 1:10. Loaded 2 μ L per lane.

Figure 9

Quality and Recovery of Pure DNA Similar When Centrifuge or Vacuum Methods Are Used for Final Eluate Collection

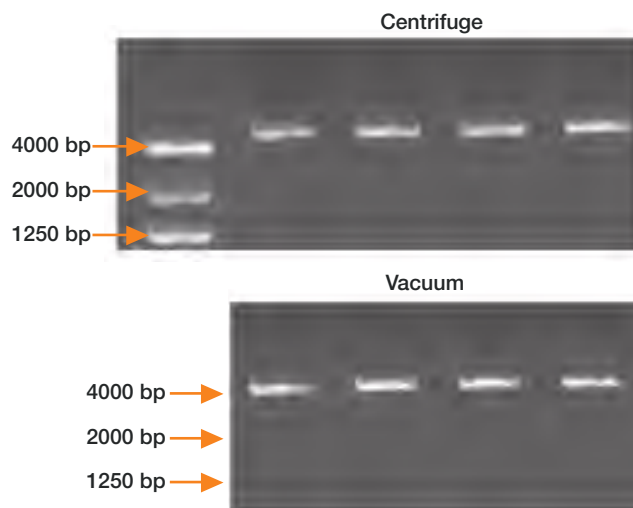

Agarose gel electrophoresis of the purified pDNA. Pall recommended protocol was followed for pDNA purification. Elution was performed by centrifuge at 1,000 \times g for 5 minutes or vacuum with 15 in. Hg (0.5 bar) for 2 minutes.

Elution conditions were analyzed for AcroPrep Advance filter plates for DNA binding using centrifugation and vacuum. Cultures of *E. coli* with pCAT plasmid DNA were lysed and DNA purified with the Pall filter plate as detailed in the recommended protocol. Plates prepared at the same time were either processed by centrifugation at 1,000 \times g or on a vacuum manifold with 15 in. Hg (0.5 bar) to elute the DNA. Volumes collected per well were determined by weighing the receiver plate before and after elution, and then random wells measured to confirm calculated average. OD at 260 nm and 280 nm was measured to calculate concentration and purity of the DNA. Figure 9 shows the prepared DNA is all in supercoil form and has similar concentration. Table 3 summarizes the purity, concentration and average volume collected from each method. Centrifugation yielded a slightly higher concentration and overall volume as compared to vacuum filtration.

Table 3

Comparison of DNA Quality and Amount From Centrifuge and Vacuum Elution Methods

Method	OD _{260/280}	Concentration	Volume/Well
Centrifuge	1.94	108 μ g/mL	61.7 μ L
Vacuum	1.94	100 μ g/mL	57.8 μ L

OD_{260/280} of purified pDNA was eluted by vacuum filtration or centrifugation. Concentration was calculated from OD₂₆₀.

Samples of pDNA purified with the Pall DNA binding filter plate and each of the competitor's filter plates were processed on an ABI 3130XL sequencer. Multiple samples from each plate were analyzed for trace score and the average contiguous read lengths (CRL). Sequence results from pDNA samples in Table 4 shows CRL for the Pall plate to be comparable with Competitor M and longer than Competitor W. In addition, the average trace score for the Pall AcroPrep Advance DNA binding plate was comparable with Competitor M and greater than Competitor W.

Table 4
Pall DNA Binding Plate Yields Sequence Quality pDNA

Glass Fiber Plate	Sample	Average Trace Score	Trace Score	Average CRL
Pall	1	52	51	> 800
	2	52		
	3	48		
Competitor M	1	52	49	> 800
	2	47		
	3	48		
Competitor W	1	33	41	> 600
	2	48		

Samples of pDNA from each filter plate were sequenced on an ABI 3130XL sequencer. Trace score is the average basecall quality value of bases in the post-trim sequence. CRL is the longest uninterrupted stretch of bases with quality higher than specified limit, in this case 20.

Discussion

The use of vacuum filtration for the clarification of plasmid purification lysates enables a rapid and effective alternative to centrifugal sedimentation. A filter plate with an integral prefilter shortens clarification times by removing the need for centrifugation. AcroPrep Advance lysate clarification filter plates have a large pore prefilter, to prevent clogging, over a more restrictive microporous filter for polishing, resulting in fast flow rates with no clogging for particulate-laden solutions. In addition, filtration in these plates allows for complete retrieval of DNA from cell lysates, removing any worry of sample loss. Once clarified, plasmid DNA samples are ready for purification on DNA binding plates.

While there are many glass fiber filter plates on the market, not all glass fiber membranes perform equally. Pall understands researchers want to ensure purification of the maximum amount of DNA when taking the time to prepare precious samples. Thus, Pall Life Sciences has created a glass fiber membrane that is optimized for DNA binding. AcroPrep Advance filter plates for DNA binding are able to bind at approximately 50% more DNA than the nearest competitor. The purified plasmid DNA is of high quality with

average OD_{260/280} ratios of 1.97. Overall this yields more pure DNA for downstream applications, such as sequencing and cloning.

Pall filter plates for DNA binding produce higher overall elution volumes on average than competitive plates. This is true when plasmid DNA is eluted by centrifuge or vacuum (data not shown). While there is a small sacrifice in concentration and elution volume when processed by vacuum over centrifugation, the total plasmid DNA yield is greater than competitive plates. The recommended vacuum protocol is designed for complete automation of the process on a liquid handling system equipped with vacuum filtration. The selection of centrifugation or vacuum elution conditions will have to be determined by the end user. The decision should take into account requirements for overall DNA yield as compared to processing time and available resources.

Note on Binding Buffers

Binding of plasmid DNA to glass fiber media is facilitated by the addition of chaotropic salts to cell lysates. Pall's recommended protocol uses guanidine-HCl (Gu-HCl). Some other protocols use Potassium Iodide (KI). The AcroPrep Advance filter plate for DNA binding is capable of plasmid binding with KI when an extra step is taken to ensure optimal elution conditions. This requires the plate to be pre-rinsed with a solution of 3M Potassium Acetate and followed by a wash with water. Once completed, plasmid DNA binding and elution can be carried out with Pall's protocol. It should be noted that OD_{260/280} value is higher, around 2.2, when using KI as binding buffer. Additionally, the OD₂₆₀ value is increased resulting in a slight overestimation of DNA concentration based solely on this measure.

Summary

- Easy to use, streamlined protocol provides maximum plasmid DNA yields when processed in manual, semi-automated, or fully-automated formats.
- Integrated prefilter on the lysate clearance plate provides consistent filtration of samples, even those containing high levels of particulates.
- High binding capacity membrane in DNA binding plate is optimized for maximum recovery of high quality plasmid DNA.
- Well geometry of the plate results in faster, more uniform filtration rates across the plate with minimal hold-up volume.
- Outlet tip geometry provides direct flow of samples into receiver plate without concerns of cross contamination.

Related Product Available From Pall

AcroPrep 384-well Filter Plates for superior performance in high throughput sample preparation applications.

AcroWell™ 96-well Filter Plates exhibit high binding capacities for proteins and nucleic acids.

Centrifugal Devices concentrate and purify samples of < 50 µL to 60 mL with efficient recovery and low non-specific binding.

Chromatography Resins simplify protein purification and fractionation for biomarker discovery, proteomics research and drug development.



Life Sciences

Pall Life Sciences

600 South Wagner Road
Ann Arbor, MI 48103-9019 USA

1.800.521.1520 USA and Canada
(+1)800.PALL.LIFE Outside USA and Canada
1.734.665.0651 phone
1.734.913.6114 fax

Visit us on the Web at www.pall.com/lab

E-mail us at LabCustomerSupport@pall.com

Australia – Cheltenham, VIC

Tel: 03 9584 8100
1800 635 082 (in Australia)
Fax: 1800 228 825

Austria – Wien

Tel: 00 1 49 192 0

Fax: 00 1 49 192 400

Brazil – São Paulo, SP

Tel: +55 11 5501 6000

Fax: +55 11 5501 6025

Canada – Ontario

Tel: 905-542-0330

800-263-5910 (in Canada)

Fax: 905-542-0331

Canada – Québec

Tel: 514-332-7255

800-435-6268 (in Canada)

Fax: 514-332-0996

800-808-6268 (in Canada)

China – P. R., Beijing

Tel: 86-10-6780 2288

Fax: 86-10-6780 2238

France – St. Germain-en-Laye

Tel: 01 30 61 32 32

Fax: 01 30 61 58 01

Lab-FR@pall.com

Germany – Dreieich

Tel: 06103-307 333

Fax: 06103-307 399

Lab-DE@pall.com

India – Mumbai

Tel: 91 (0) 22 67995555

Fax: 91(0) 22 67995556

Italy – Buccinasco

Tel: +3902488870.1

Fax: +39024880014

Japan – Tokyo

Tel: 03-6901-5800

Fax: 03-5322-2134

Korea – Seoul

Tel: 82-2-560-8711

Fax: 82-2-569-9095

Malaysia – Selangor

Tel: +60 3 5569 4892

Fax: +60 3 5569 4896

Poland – Warszawa

Tel: 22 510 2100

Fax: 22 510 2101

Russia – Moscow

Tel: 5 01 787 76 14

Fax: 5 01 787 76 15

Singapore

Tel: 65 6 389-6500

Fax: 65 6 389-6501

South Africa –

Johannesburg

Tel: +27-11-2662300

Fax: +27-11-3253243

Spain – Madrid

Tel: 91-657-9876

Fax: 91-657-9836

Sweden – Lund

Tel: (0)46 158400

Fax: (0)46 320781

Switzerland – Basel

Tel: 061-638 39 00

Fax: 061-638 39 40

Switzerland – Fribourg

Tel: +41 (0)26 350 53 00

Fax: +41 (0)26 350 53 53

Taiwan – Taipei

Tel: 886 2 2545 5991

Fax: 886 2 2545 5990

Thailand – Bangkok

Tel: 66 2937 1055

Fax: 66 2937 1066

United Kingdom –

Farington

Tel: 02392 302600

Fax: 02392 302601

Lab-UK@europe.pall.com

© 2010, Pall Corporation. Pall, , AcroPrep, AcroWell, Nanosep, and Supor are trademarks of Pall Corporation. ® indicates a trademark registered in the USA. **Filtration.Separation.Solution.sm** is a service mark of Pall Corporation.